

Charbro®



GAS HEATERS

MODEL NOS: DEVIL 700, 900/910SS, 1600/
1610SS & 2100

PART NOS: 6920182, 6920186, 6920188, 6920190, 6920192, &6920194

USER INSTRUCTIONS



GC0816

INTRODUCTION

Thank you for purchasing this CLARKE Gas Powered Heater.

Before attempting to use this product, please read this manual thoroughly and follow the instructions carefully. In doing so you will ensure the safety of yourself and that of others around you, and you can look forward to your purchase giving you long and satisfactory service.

GUARANTEE

This product is guaranteed against faulty manufacture for a period of 12 months from the date of purchase. Please keep your receipt which will be required as proof of purchase.

This guarantee is invalid if the product is found to have been abused or tampered with in any way, or not used for the purpose for which it was intended.

Faulty goods should be returned to their place of purchase, no product can be returned to us without prior permission.

This guarantee does not effect your statutory rights.

ENVIRONMENTAL RECYCLING POLICY



Through purchase of this product, the customer is taking on the obligation to deal with the WEEE in accordance with the WEEE regulations in relation to the treatment, recycling & recovery and environmentally sound disposal of the WEEE.

In effect, this means that this product must not be disposed of with general household waste. It must be disposed of according to the laws governing Waste Electrical and Electronic Equipment (WEEE) at a recognised disposal facility.

If disposing of this product or any damaged components, do not dispose of with general waste. This product contains valuable raw materials. Metal products should be taken to your local civic amenity site for recycling of metal products.

SAFETY INFORMATION



WARNING: LACK OF VENTILATION CAN CAUSE CARBON MONOXIDE POISONING.

WARNING: CARBON MONOXIDE POISONING CAN KILL.

Signs of Carbon Monoxide poisoning are headaches, dizziness and/or nausea. Should anyone show these signs, they must GET FRESH AIR IMMEDIATELY. Turn off the heater and have it serviced before using again.

Pregnant women, persons with a heart or lung condition, anaemia or under the influence of alcohol, or those at high altitude, are more likely to be effected by Carbon Monoxide.



Read, and make sure you fully understand the following precautions and the hazards associated with this type of heater.

- Use only liquid propane gas with this heater.
- Ensure the Propane gas bottle, gas hose and electric cable, are positioned behind the unit, well away from the heat.
- Ensure gas hose and regulator connections are gastight and the hose is not kinked.
- Never use the heater where flammable vapours or if a high dust content is present in the air.
- Only use with the voltage specified and ensure the heater is properly earthed.
- Use only in well ventilated areas. Provide ventilation of at least 3 square feet of fresh air for every 100,000 BTU/hr of rating.
- The minimum clearance from any combustible materials is 4 feet (125cm) between the rear, top or sides of the heater and walls or other obstructions.
- Keep the heater at least 6 feet from propane tanks and do not point the heater at propane tanks within 20 feet.
- Stand the heater on a stable, level surface whilst hot or operating. If the heater should overturn, a fire could occur.
- Keep children and animals away from heater at all times.
- Use heater in accordance with all fire regulations.
- Never use heater for domestic heating in living or sleeping areas.
- Never leave a heater plugged in without adult supervision if children or animals are likely to be present.

- Never move, handle, replenish the gas supply or service the heater when it is hot, operating or plugged in.
- Never attach the heater to any duct work, or impede air flow into or out of the heater.
- Disconnect the heater from the power supply when not in use.
- Use ONLY the factory pre-set regulator supplied with the heater.
- If the heater works for long periods at maximum capacity, be aware that it is possible for ice to form on the gas cylinder due to excessive evaporation.
- Never direct hot air towards the cylinder in order to de-ice.
- Never use in wet areas, basements or below ground level. Propane gas is heavier than air and will sink to the lowest possible level.
- Always ensure the heater is correctly maintained in accordance with this manual.

SAFETY SYMBOLS

Please read all of the safety and operating instructions carefully before using this product. The following safety symbols may be found on the product.

	General hazard warning		Danger-Hot Surfaces.
	Always read the manual before use		

ELECTRICAL CONNECTIONS



WARNING! Read these electrical safety instructions thoroughly before connecting the product to the mains supply.

Before switching the product on, make sure that the voltage of your electricity supply is the same as that indicated on the rating plate. This product is designed to operate on 230VAC 50Hz. Connecting it to any other power source may cause damage.

This product may be fitted with a non-rewireable plug. If it is necessary to change the fuse in the plug, the fuse cover must be refitted. If the fuse cover becomes lost or damaged, the plug must not be used until a suitable replacement is obtained.

If the plug has to be changed because it is not suitable for your socket, or due to damage, it should be cut off and a replacement fitted, following the wiring instructions shown below. The old plug must be disposed of safely, as insertion into a mains socket could cause an electrical hazard.



**WARNING! The wires in the power cable of this product are coloured in accordance with the following code:
Blue = Neutral Brown = Live Yellow and Green = Earth**

If the colours of the wires in the power cable of this product do not correspond with the markings on the terminals of your plug, proceed as follows.

- The wire which is coloured **Blue** must be connected to the terminal which is marked **N** or coloured **Black**.
- The wire which is coloured **Brown** must be connected to the terminal which is marked **L** or coloured **Red**.
- The wire which is coloured **Yellow and Green** must be connected to the terminal which is marked **E** or  or coloured **Green**.

Plug must be BS1363/A approved.

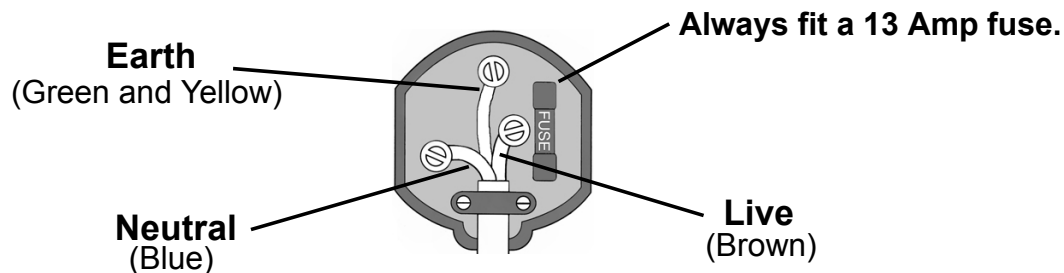

Ensure that the outer sheath of the cable is firmly held by the clamp

We strongly recommend that this machine is connected to the mains supply via a Residual Current Device (RCD)

If in any doubt, consult a qualified electrician. DO NOT attempt any repairs yourself.

UNPACKING

When unpacking, check the heater for possible shipping damage. Should any damage be apparent, please notify your Clarke dealer immediately.

Your heater is fully assembled,- only the electrical and gas supplies need connecting. Retain any plastic cover caps (attached to the inlet connector and hose/regulator assembly) for future storage.

PROPANE GAS SUPPLY

These heaters are designed for use with PROPANE GAS ONLY. Gas cylinders are not supplied, but are readily available from builders merchants or gas suppliers etc.

This range of portable, direct fired gas heaters is designed to BS 4096 for industrial applications to give safe, efficient and reliable operation.

As with all mechanical equipment, optimum performance will only be achieved if the correct operation and servicing procedures are followed.



WARNING: PROPANE GAS CYLINDERS MUST BE USED AND STORED IN ACCORDANCE WITH THE HIGHLY FLAMMABLE LIQUIDS AND LIQUEFIED PETROLEUM GASES REGULATIONS 1972'

GAS CONNECTION

Connect the free end of the gas hose to the gas inlet connection on the heater and tighten to ensure there are no gas leaks. Before attaching the regulator to the gas cylinder, ensure the mating parts are free from grease and dirt and are undamaged.

Fit the regulator to the cylinder, tightening the thread as tight as possible with a propane spanner, noting that the threads are LEFT HANDED. To check for leaks, use soapy water or liquid soap applied to each of the connections. Any bubbles formed indicate a leak. Correct all leaks immediately.

IMPORTANT: The gas hose and cylinder must ALWAYS be located well behind the heater.

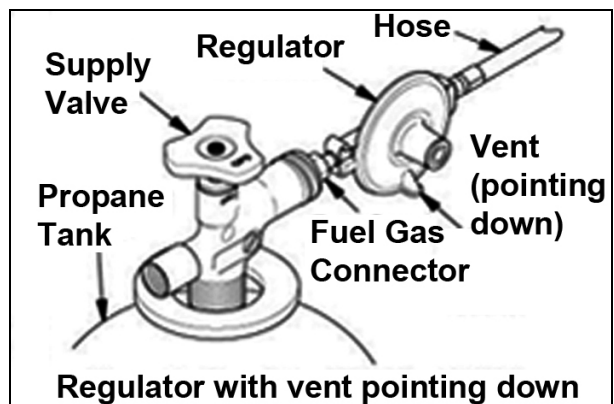

In order to reduce the risk of icing up when operating at long periods at maximum capacity, you should use a larger capacity gas bottle, or two/ three bottles in parallel, as shown in Fig 2.

- The 'Tee' piece and 'pigtaills' are readily available from your builders merchants or gas supplier.

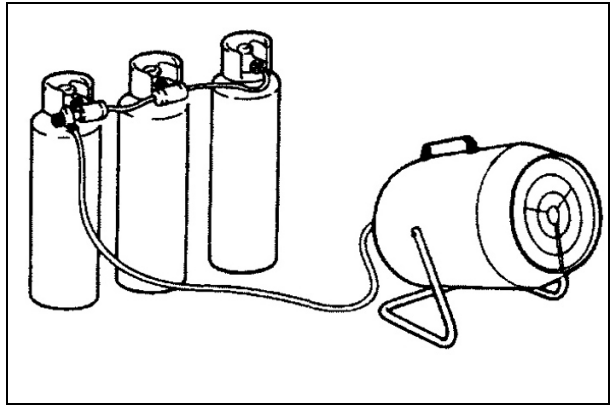

CHANGING GAS BOTTLES

1. Turn off the heater and disconnect from the electrical supply.
2. Close the gas valve on the bottle and unscrew the regulator, (left hand thread).
3. Ensure the replacement bottle screw threads and gas orifice is perfectly clean before screwing in the regulator valve tightly.
4. Check to ensure there are no leaks using soapy water and when satisfied, plug in to the electrical supply and restart the heater.

OPERATING SPACE AND AIR SUPPLY

MINIMUM FRESH AIR OPENING REQUIREMENTS

As a general rule of thumb, an opening of 1 in² per 1000 Btu/hr is a minimum requirement.

These heaters are specified as requiring a minimum ventilation of 3 sq/ ft per 100,000BTU/hr.

OPERATING SPACE

Do not obstruct the air intake to the heater and allow 4 feet (125cm) between rear, top and sides and walls or other obstructions.

PRINCIPLE OF OPERATION

Understanding the basic operation of the heater will reinforce the need to maintain the unit in top condition at all times, whilst always observing the safety precautions.

The heater comprises four basic systems:

1. The gas system.
2. The air system.
3. The ignition system.
4. The safety control system.

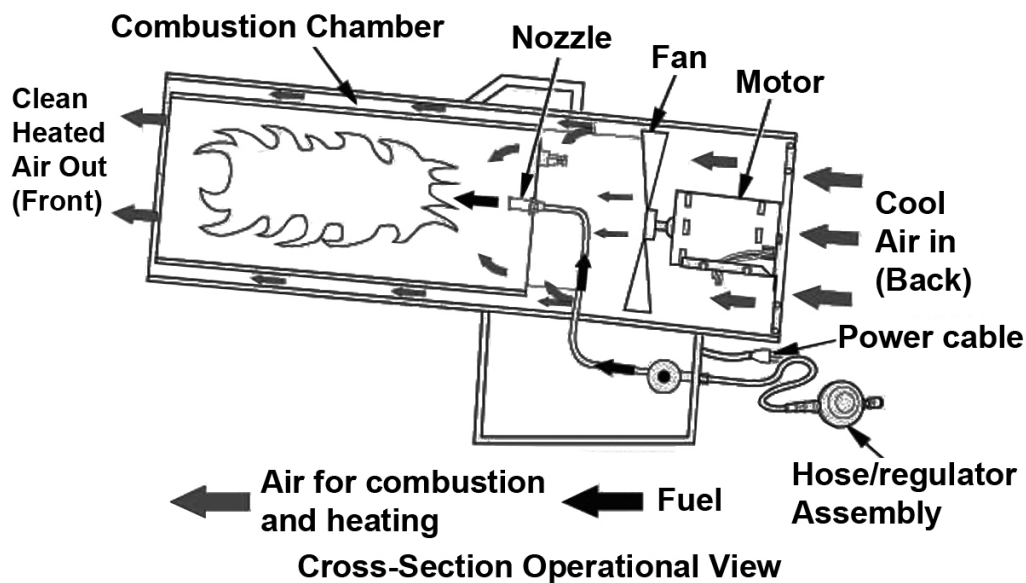

AIR SYSTEM

An axial fan, which is energised when switching on, provides the air flow through the combustion chamber to provide a stream of hot air from the heater.

GAS SYSTEM

The gas supply to the machine is by means of a high pressure hose, connected to an LPG (Liquid Propane Gas) cylinder, via a pressure regulator.

When the mains supply is switched on, the Safety Shut-off valve solenoid is energised, allowing the gas to flow to the Flame Failure valve, and when the failure valve override knob is depressed, gas flows to the burner head.

IGNITION SYSTEM

Ignition is automatic with this heater as soon as the gas valve button is depressed, with a continuous spark from the spark plug igniting the gas. As the thermocouple heats up, a low voltage is fed to the Flame Failure valve, causing the valve to open, so that after a few seconds, the gas valve button may be released and the flame is established.

SAFETY CONTROL SYSTEM

Should the flame extinguish for any reason, the thermocouple will quickly cool, causing the Flame Failure valve to close, shutting off the gas supply.

Similarly, should there be a power failure, causing the fan motor to stop, the Safety Shut-Off valve solenoid will become de-energised, and therefore shut off the gas supply.

Additionally, the machine is equipped with thermal overload protection, which will intervene should the unit overheat, shutting off the electrical supply.

STARTING PROCEDURE



WARNING: BEFORE STARTING THE HEATER, YOU MUST ENSURE THAT THE MINIMUM VENTILATION REQUIREMENTS ARE OBSERVED TO AVOID THE RISK OF CARBON MONOXIDE POISONING.

1. Ensure there is sufficient gas and that it is correctly connected.
2. Open the supply valve on the gas cylinder, and fully open the regulator valve adjacent to the gas inlet pipe.
3. Plug the heater in to a suitable power supply.
4. Set the flame intensity control valve (B), to a low setting,
5. Set the fan switch (A) to the ON (I) position. Confirm the fan operates.
6. Hold in the gas valve button (C), until the thermocouple is energised and the heater ignites.
7. If the heater fails to ignite, there may be air in the hose so keep the fuel valve open and wait for about 15 seconds. Wait 30 seconds for unburned fuel to exit the heater. Repeat the step above.

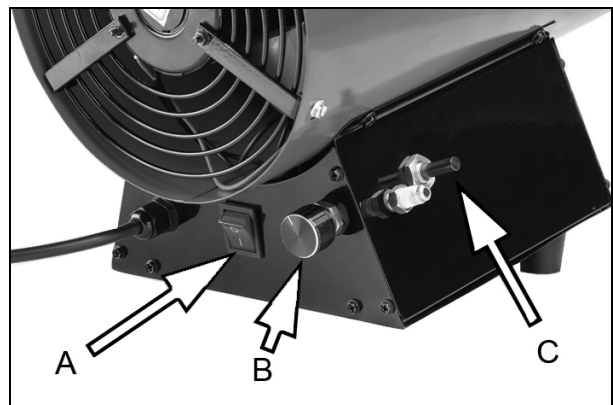

8. When the burner remains lit, set the heater at the required level by turning the flame intensity control valve counter-clockwise. If the burner goes out, turn off the gas. Turn the gas valve fully clockwise to its lowest position. Check the fuel supply. If adequate fuel is available, re-start the heater from step 1.

Should the flame extinguish when the ignition button is released, wait for 1 minute, before repeating the operation.

- Turning the flame intensity control valve anti-clockwise will increase the gas supply and therefore the output, clockwise to decrease.

If ignition is difficult or irregular, ensure the fan is operating and that the air inlet and outlet are completely clear. Also ensure that the electrode gap is correct, and that the electrode is clean (see Maintenance).

IMPORTANT:

Should the thermal overload protection feature operate and the spark plug is seen to be operating, shut off the gas supply and allow the unit to cool for at least 10 minutes with the fan running, before attempting to relight the burner.

Should the flame safety valve operate, the heater may be restarted once the cause of the problem has been found and rectified.

SHUT-DOWN PROCEDURE

1. Turn off the gas at the propane cylinder valve(s).
2. Let the heater run while any gas left in the supply hoses is burnt off.
3. Allow the fan to run for 2 - 3 minutes with the burner off, in order to allow the casing to cool down and the fan to disperse any residual gas.
4. Switch off the fan and unplug from the electrical supply.
5. Disconnect the gas supply.

STORAGE



CAUTION: DISCONNECT THE HEATER FROM THE PROPANE SUPPLY CYLINDER(S)

1. Store the propane gas cylinders in a safe manner outdoors and keep them below 100deg F (37 deg C).
2. Place protective bags over fittings & connectors and store in a clean, dry place.
3. Fit the plastic cover caps which were removed when unpacking, over the connections they covered when received.
4. When removing from storage, always check inside of heater for debris/ foreign objects before returning to use. Do not store the hose/regulator inside the combustion chamber.

MAINTENANCE



WARNING: BEFORE CARRYING OUT ANY ADJUSTMENT OR MAINTENANCE, ENSURE THE HEATER IS SWITCHED OFF, DISCONNECTED FROM THE MAINS AND GAS SUPPLY, AND HAS BEEN GIVEN ADEQUATE TIME TO COOL DOWN.

It is essential that the heater is correctly maintained and kept in top condition at all times.

All models are similar, in that access to the control components is gained by removing the access panel under the base of the heater which is secured by screws around the edge.

MONTHLY (WHEN IN CONSTANT USE)

Check the spark plug for cleanliness and correct operation. Have the gap re-set to no more than 5mm by your Clarke service engineer.

Check the condition of the gas hose. If there are any signs of deterioration, it should be renewed using only a Clarke original spare part.

Ensure that all connections are clean and secure.

When necessary, clean the fan and the inside of the heater thoroughly.

The use of parts other than genuine Clarke replacement parts may result in safety hazards or decreased performance, and will invalidate your warranty.

TROUBLESHOOTING

PROBLEM	CAUSE	REMEDY
Motor does not start.	No power.	Check power supply, power cable and fuse, and replace if necessary.
	Faulty motor/capacitor. Fan blades bent.	Check & replace if necessary.
	Lock out of appliance due to overheating. Thermal cut-out in operation.	Identify cause of overheating. Wait for 5 mins and restart. If condition persists, contact your Clarke dealer for advice.
Spark plug does not spark.	Gap incorrect, faulty connection	Clean and reset gap if necessary or replace.
Heater will not ignite	Connection/installation incorrect.	Check that installation instructions are followed.
	No spark at spark plug due to loose HT lead or PCB fault.	Check spark plug wire. Tighten or re-attach if loose. If condition persists, contact your Clarke dealer for advice.
Heater stops during operation.	Excessive or insufficient gas supply.	Check pressure regulator & replace if necessary.
		Check that fan motor works properly.
		Check, and use a larger cylinder, or two or more in parallel.
		Check there are no obstructions to air flow. Check ventilation is adequate. See also 'Motor does not Start'.
No gas flow to the burner.	Cylinder gas tap closed.	Open the gas tap.
	Cylinder is empty.	Replace cylinder.
	Nozzle is obstructed.	Remove nozzle & clean.
	Gas leaks from supply hose or from tap.	Use soapy water to find the leak and repair.

PROBLEM	CAUSE	REMEDY
Burner starts but stops as the gas valve button is released.	Thermocouple is not warm enough or is faulty.	Repeat the starting operation, keeping the gas valve button depressed for longer.
	Weak gas supply.	Increase flame intensity control valve setting.

SPECIFICATIONS

Model Number	700	900/910SS	1600/1610ss	2100
Dimensions (LxWxH) mm	425x215x340	500x215x370	500x215x370	640x220x385
Weight	5.3 kg	6.4 kg	6.4 kg	8.0 kg
Fuse Rating	13A	13A	13A	13A
Operating Voltage	230V/50Hz	230V/50Hz	230V/50Hz	230V/50Hz
Rated Input Power	90 W	110W	110W	135 W
Rated Input	0.7 A	0.7 A	0.7 A	0.7 A
Gas Consumption (kg/hr)	0.63 -1.05	1.16-1.79	1.59-2.63	3.0-3.86
Air Flow (m3/hr)	500	535	580	690
Gas Pressure (max)	300mBar	300mBar	300mBar	300mBar
Min Heat Output (kW/btu)	8.8/30,000	17.6/60,000	22/75,000	35.2/120,000
Max Heat Output (kW/btu)	14.6-50,000	24.9/85000	36.6/125,000	49.8/170,000

Please note that the details and specifications contained herein are correct at the time of going to print. However CLARKE International reserve the right to change specifications at any time without prior notice. Always consult the heater's data plate.

PARTS DIAGRAM - DEVIL 700/900/910SS

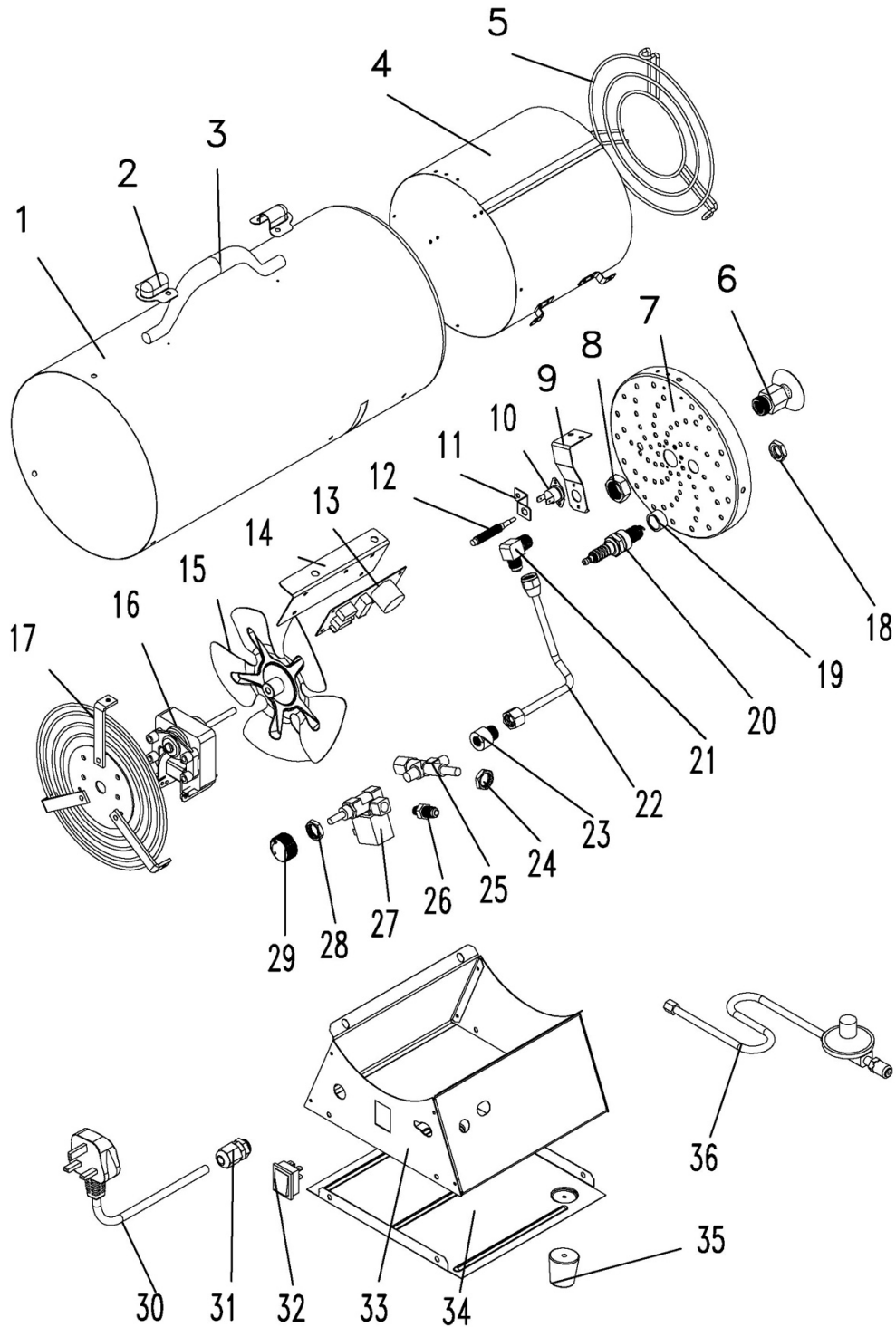

PARTS LIST DEVIL - 700/900/910SS

No	Description	No	Description
1	Outer Shell	19	Spark Plug Washer
2	Handle Mounting clips	20	Spark Plug
3	Handle	21	Elbow Fitting
4	Middle Cylinder	22	Fuel Tube Assembly
5	Front Guard	23	Extension Fitting
6	Orifice Assembly	24	Securing Nut
7	Flame Holder Assembly	25	Gas Valve
8	Orifice Nut	26	Male Fitting Connector
9	High Limit Switch Bracket	27	Solenoid Valve Assembly
10	High Limit Switch	28	Solenoid Valve Assembly Nut
11	Thermocouple Bracket	29	Flame Intensity Control Knob
12	Thermocouple	30	Power Cable Assembly
13	Flame Control PCB	31	Strain Relief Bush
14	Flame Control Bracket	32	Power Switch
15	Fan	33	Control Box
16	Motor Assembly	34	Access Panel
17	Inlet Grille	35	Rubber Foot
18	Spark Plug Nut	36	Hose/Regulator Assembly

PARTS DIAGRAM - DEVIL 1600

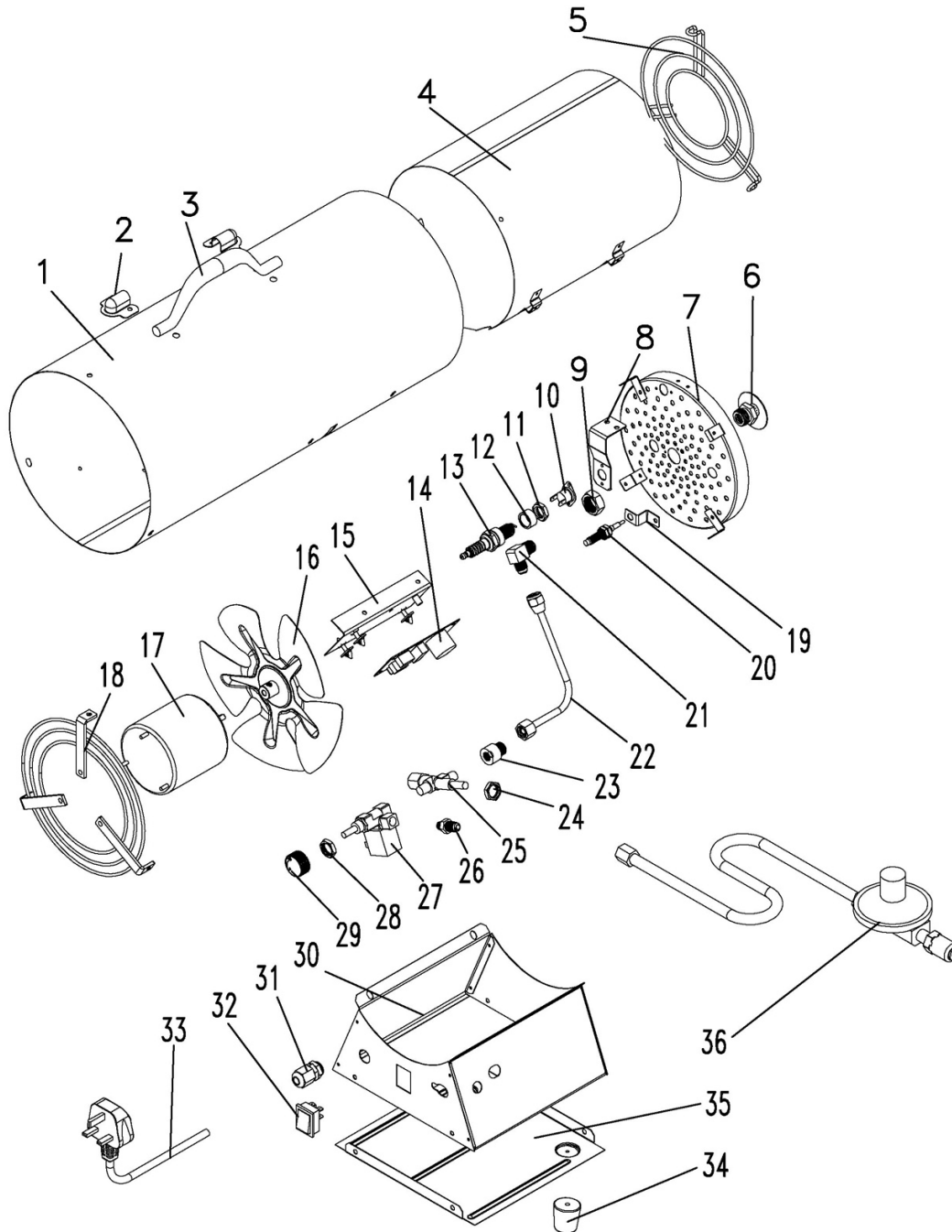

PARTS LIST - DEVIL 1600

No	Description	No	Description
1	Outer Shell	19	Thermocouple Bracket
2	Handle Mounting Clips	20	Thermocouple
3	Handle	21	Elbow Fitting
4	Middle Cylinder	22	Fuel Tube Assembly
5	Front Guard	23	Extension Fitting
6	Orifice Assembly	24	Securing Nut
7	Flame Holder Assembly	25	Gas Valve
8	High Limit Switch Bracket	26	Male Connector Fitting
9	Orifice Nut	27	Solenoid Valve Assembly
10	High Limit Switch	28	Solenoid Valve Assembly Nut
11	Spark Plug Nut	29	Flame Intensity Control Knob
12	Spark Plug Washer	30	Control Box
13	Spark Plug	31	Strain Relief Bush
14	Flame Control PCB	32	Power Switch
15	Flame Control Bracket	33	Power Cable Assembly
16	Fan	34	Rubber Foot
17	Motor Assembly	35	Access Panel
18	Inlet Grille	36	Hose/Regulator Assembly

PARTS DIAGRAM - DEVIL 1610SS

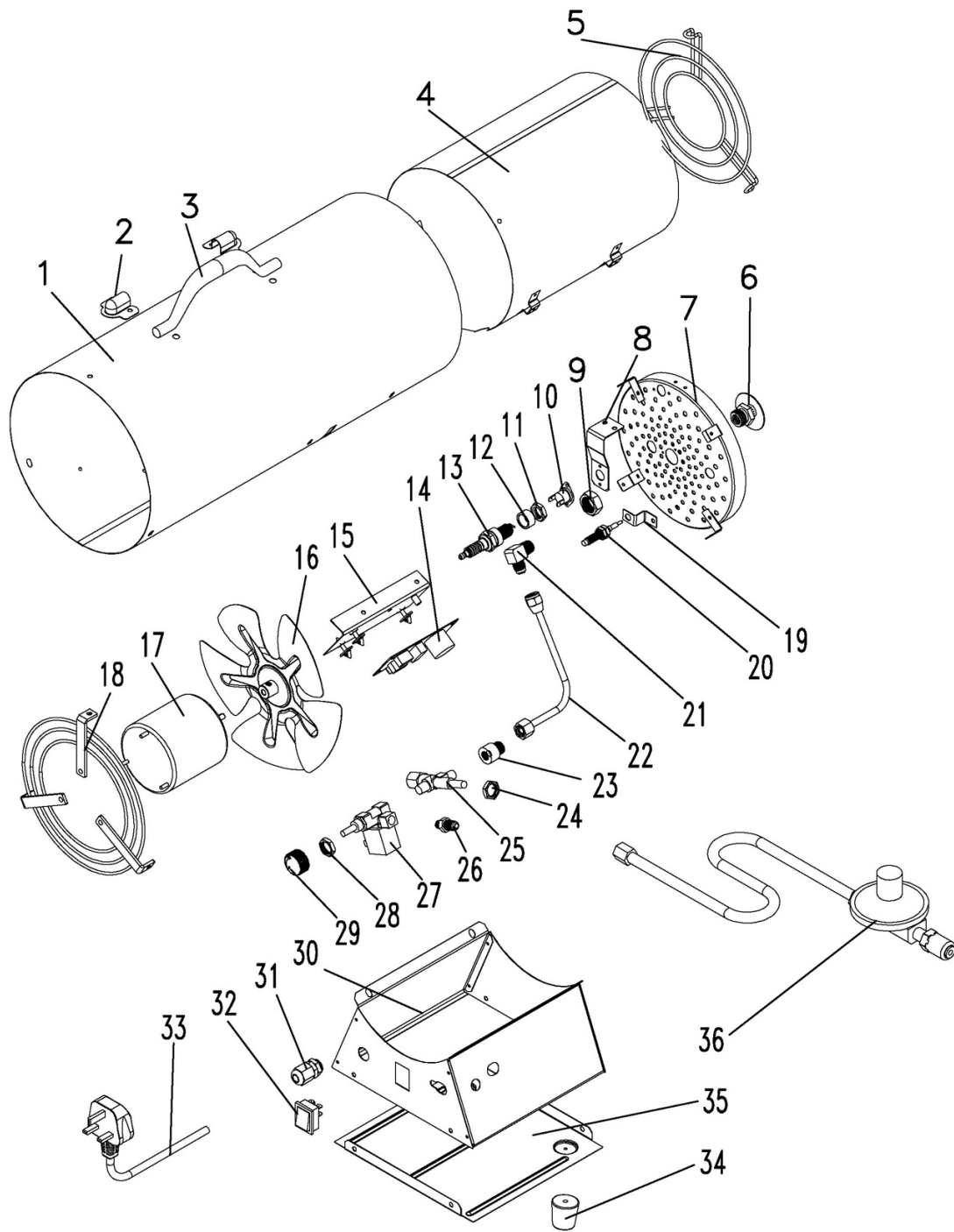

PARTS LIST - DEVIL 1610SS

No	Description	No	Description
1	Outer Shell	19	Thermocouple Bracket
2	Handle Mounting Clips	20	Thermocouple
3	Handle	21	Elbow Fitting
4	Middle Cylinder	22	Fuel Tube Assembly
5	Front Guard	23	Extension Fitting
6	Orifice Assembly	24	Securing Nut
7	Flame Holder Assembly	25	Gas Valve
8	High Limit Switch Bracket	26	Male Fitting Connector
9	Orifice Nut	27	Solenoid Valve Assembly
10	High Limit Switch	28	Solenoid Valve Assembly Nut
11	Spark Plug Nut	29	Flame Intensity Control Knob
12	Spark Plug Washer	30	Control Box
13	Spark Plug	31	Strain Relief Bush
14	Flame Control PCB	32	Power Switch
15	Flame Control Bracket	33	Power Cable Assembly
16	Fan	34	Rubber Foot
17	Motor Assembly	35	Access Panel
18	Inlet Grille	36	Hose/Regulator Assembly

PARTS DIAGRAM - DEVIL 2100

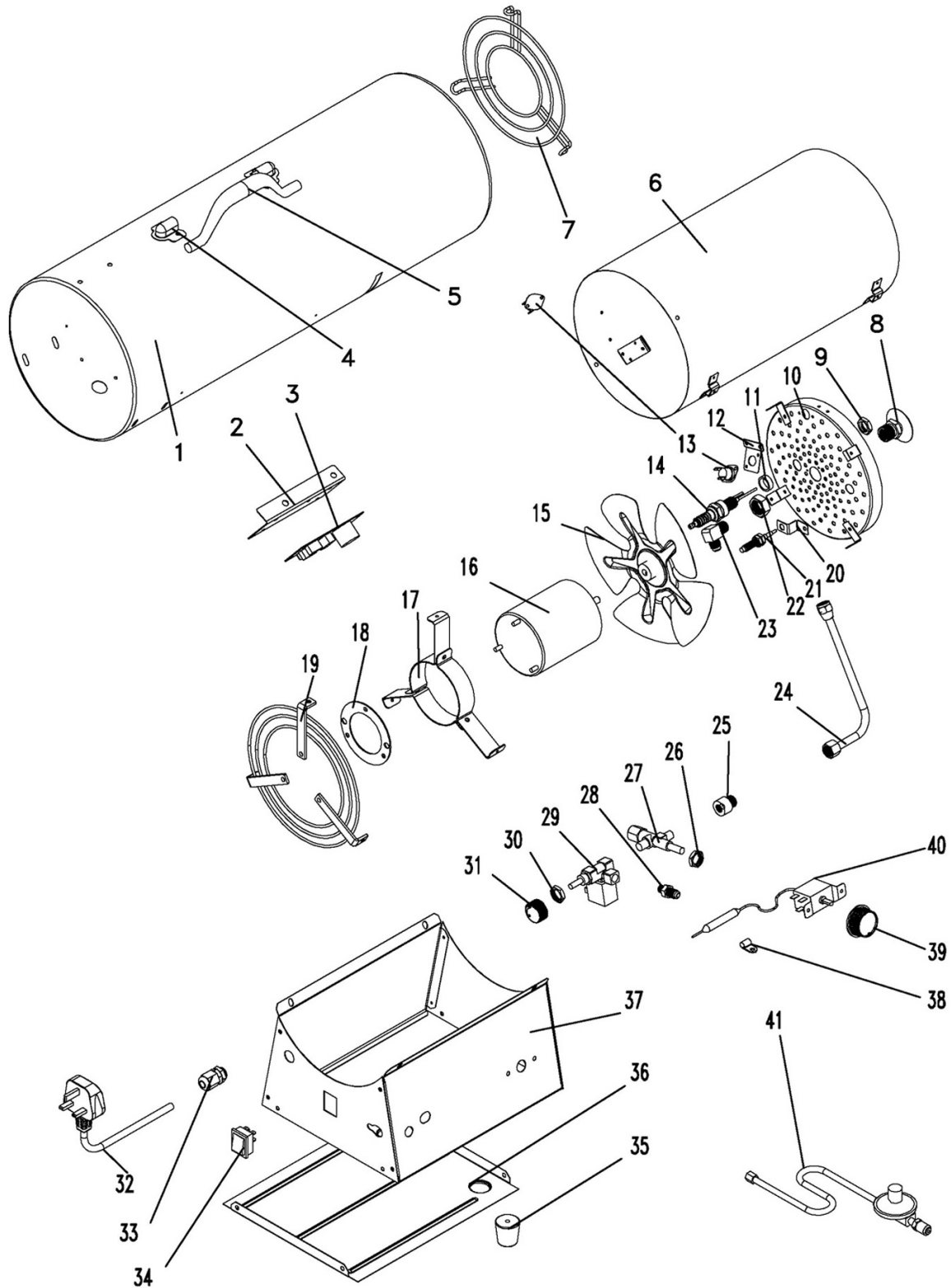

PARTS LIST - DEVIL 2100

No	Description	No	Description
1	Outer Shell	20	Thermocouple Bracket
2	Flame Control PCB	21	Thermocouple
3	Flame Control PCB Bracket	22	Orifice Nut
4	Handle Mounting Clips	23	Elbow Fitting
5	Handle	24	Fuel Tube Assembly
6	Middle Cylinder	25	Extension Fitting
7	Front Guard	26	Securing Nut
8	Orifice Assembly	27	Gas Valve Button
9	Spark Plug Nut	28	Male Fitting Connector
10	Flame Holder Assembly	29	Solenoid Valve Assembly
11	Spark Plug Washer	30	Solenoid Valve Assembly Nut
12	High Limit Switch Bracket	31	Flame Intensity Control Knob
13	High Limit Switch	32	Power Cable Assembly
14	Spark Plug	33	Strain Relief Bush
15	Fan	34	Power Switch
16	Motor Assembly	35	Rubber Foot
17	Motor Mounting Bracket	36	Access Panel
18	Bracket	37	Control Box
19	Inlet Grille	38	Hose/Regulator Assembly

WIRING DIAGRAMS

Wiring - Devil 700/900/910ss/1600/1610ss

CONNECTION DIAGRAM

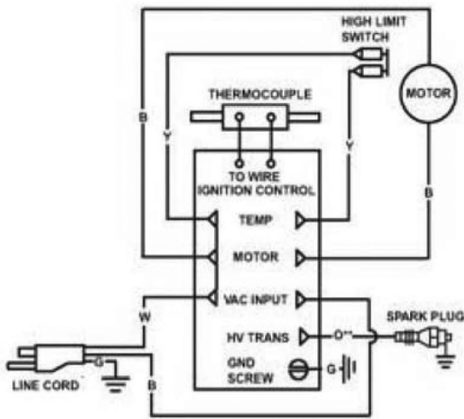

SCHEMATIC DIAGRAM

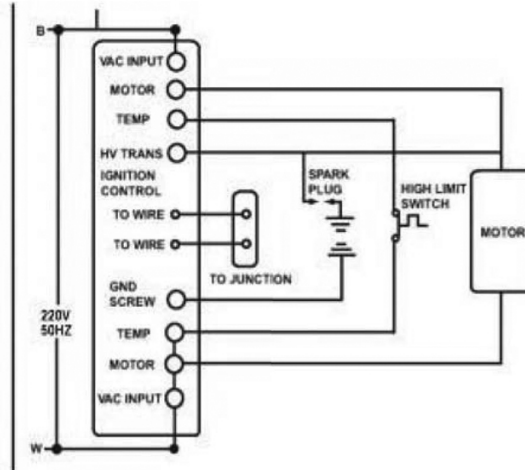

• If any original wiring as supplied with the heater must be replaced, it must be replaced with type AWG 105° C wire or its equivalent except as indicated (*Type SF2-200, **SG1-250° C)

Wiring - Devil 2100

Connection Diagram

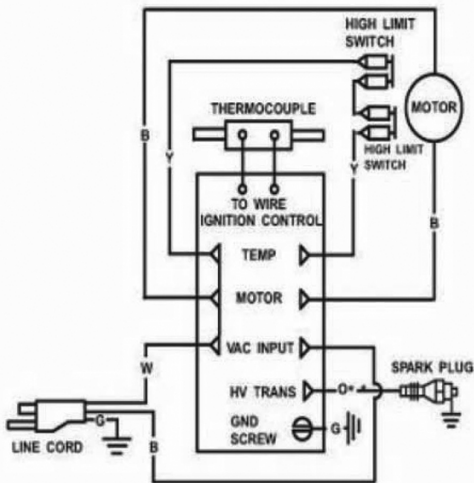

Schematic Diagram

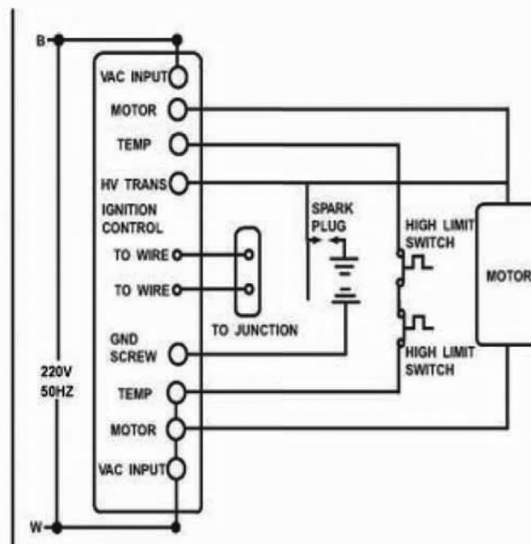

DECLARATION OF CONFORMITY



Clarke[®]
INTERNATIONAL

Hemnall Street, Epping, Essex CM16 4LG

DECLARATION OF CONFORMITY

This is an important document and should be retained.

We hereby declare that this product(s) complies with the following directive(s):

2014/35/EU *Low Voltage Equipment Directive.*
2014/30/EU *Electromagnetic Compatibility Directive.*
2009/142/EC *Gas Appliance Directive*
2011/65/EU *Restriction of Hazardous substances.*

The following standards have been applied to the product(s):

*DIN EN 13785:2010, EN 60335-1:2012/A11: 2014, EN 60335-2-102:2006/A1:2010,
EN 55014-1:2006/A2:2011, EN 55014-2:1997/A2:2008, EN 61000-3-2:2014, EN 61000-3-3:2013.*

The technical documentation required to demonstrate that the product(s) meet(s) the requirement(s) of the aforementioned directive(s) has been compiled and is available for inspection by the relevant enforcement authorities.

The CE mark was first applied in: 2011

Product Description: Gas Heaters
Model number(s): Little Devil II, Little Devil II-SS, Devil 700,710-SS, 900,910-SS,1600,
1610-SS, 2100,4000.
Serial / batch Number: N/A
Date of Issue: 16/08/2016

Signed:

J.A. Clarke
Director

A SELECTION FROM THE VAST RANGE OF

Clarke®

QUALITY PRODUCTS



AIR COMPRESSORS
From DIY to industrial, Plus air tools, spray guns and accessories.

GENERATORS
Prime duty or emergency standby for business, home and leisure.

POWER WASHERS
Hot and cold, electric and engine driven - we have what you need

WELDERS
Mig, Arc, Tig and Spot.
From DIY to auto/industrial.

METALWORKING
Drills, grinders and saws for DIY and professional use.

WOODWORKING
Saws, sanders, lathes, mortisers and dust extraction.

HYDRAULICS
Cranes, body repair kits, transmission jacks for all types of workshop use.

WATER PUMPS
Submersible, electric and engine driven for DIY, agriculture and industry.

POWERTOOLS
Angle grinders, cordless drill sets, saws and sanders.

STARTERS/CHARGERS
All sizes for car and commercial use.



PARTS & SERVICE: 0208 988 7400
E-mail: Parts@clarkeinternational.com or Service@clarkeinternational.com
SALES: UK 01992 565333 or Export 00 44 (0)1992 565335

Clarke INTERNATIONAL Hemnall Street, Epping, Essex CM16 4LG
www.clarkeinternational.com