

**blacklinesafety**

EXO

Technical User Manual

# Contents

- 1 EXO OVERVIEW ..... 8**
  - 1.1 EXO PUMP .....8
    - 1.1.1 In the Box..... 8
    - 1.1.2 Hardware Details ..... 9
  - 1.2 EXO DIFFUSION.....12
    - 1.2.1 In the Box..... 12
    - 1.2.2 Hardware Details ..... 13
    - 1.2.3 Wind Guard ..... 15
  - 1.3 BLACKLINE SAFETY SERVICE PLANS .....16
  - 1.4 BLACKLINE SAFETY SERVICES .....16
    - 1.4.1 Blackline Safety Monitoring ..... 16
    - 1.4.2 Blackline Live ..... 17
    - 1.4.3 Blackline Analytics ..... 17
  - 1.5 COMMUNICATION INTERVALS.....17
  - 1.6 CONNECTION MODULES .....17
    - 1.6.1 Cellular Connection Module ..... 18
    - 1.6.2 Satellite Connection Module ..... 18
    - 1.6.3 Determining if a Satellite Module is Installed ..... 18
- 2 CARTRIDGES ..... 19**
  - 2.1 CARTRIDGE OPTIONS .....19
  - 2.2 CHANGING CARTRIDGES.....20
  - 2.3 SENSOR CONTAMINANTS .....20
  - 2.4 CARTRIDGES AND EXTREME WEATHER.....20
- 3 SETUP ..... 21**
  - 3.1 LOCATION.....21
    - 3.1.1 Determining Location ..... 22
  - 3.2 MOUNTING.....22
    - 3.2.1 Mounting Point Layout ..... 24

- 3.3 SETUP WIZARD .....25
- 3.4 CONNECTIVITY LIGHT .....26
- 4 OPERATION ..... 26**
- 4.1 EXO PUSH BUTTONS .....26
- 4.2 POWERING ON EXO .....27
  - 4.2.1 Powering Off EXO ..... 28
- 4.3 EXO LCD DISPLAY .....28
  - 4.3.1 Main Menu..... 28
  - 4.3.2 Gas Status Screen.....28
  - 4.3.3 Banner ..... 29
- 4.4 EXO BATTERY.....30
  - 4.4.1 Battery Life ..... 31
  - 4.4.2 Battery Storage..... 31
  - 4.4.3 Battery Gauge ..... 31
- 4.5 CHARGING EXO .....32
  - 4.5.1 Using the Quick Charger ..... 32
  - 4.5.2 Trickle Charger ..... 33
- 4.6 MAINTENANCE CODE .....34
- 4.7 ALARM TEST .....34
- 4.8 SIREN .....35
- 4.9 SPEAKER .....36
- 5 OPERATIONAL NOTIFICATIONS ..... 36**
- 5.1 ACKNOWLEDGING OPERATIONAL NOTIFICATIONS.....36
- 5.2 OPERATIONAL NOTIFICATION TYPES .....37
- 6 LOW URGENCY NOTIFICATIONS..... 38**
- 6.1 ACKNOWLEDGING LOW URGENCY NOTIFICATIONS .....39
- 6.2 LOW URGENCY NOTIFICATION TYPES.....39
- 7 HIGH URGENCY NOTIFICATIONS..... 42**
- 7.1 ACKNOWLEDGING HIGH URGENCY NOTIFICATIONS .....42
- 7.2 HIGH URGENCY NOTIFICATION TYPES.....42
- 7.3 LIVE RESPONSE .....44

<b>8</b>	<b>GAS DETECTION.....</b>	<b>44</b>
8.1	BUMP TEST.....	44
8.1.1	Manual Bump Test.....	45
8.2	CALIBRATION.....	47
8.2.1	Manual Calibration .....	47
8.3	ZERO SENSORS .....	49
8.3.1	Manual Zero Sensors.....	49
8.4	LEL SENSOR PRECAUTIONS.....	50
8.5	PID TARGET GASES .....	52
8.6	GAS ALERT COUNTDOWN.....	53
<b>9</b>	<b>GAS INLETS.....</b>	<b>54</b>
9.1	MANUAL CALIBRATION INLET.....	54
9.2	PUMP INLETS .....	54
9.3	GAS SAMPLING .....	55
9.4	PUMP BLOCKED.....	56
<b>10</b>	<b>FEATURES .....</b>	<b>57</b>
10.1	TEXT MESSAGES.....	57
10.2	TWO-WAY VOICE CALLS .....	58
10.3	PUSH-TO-TALK (PTT).....	59
10.4	AVAILABLE CHANNELS .....	59
10.4.1	Changing Channels.....	60
10.5	AIRPLANE MODE.....	61
10.6	STEALTH.....	61
10.7	LOCAL TIME.....	62
10.7.1	Setting Local Time on EXO.....	63
10.8	TIMER.....	65
10.9	STOPWATCH.....	67
<b>11</b>	<b>ELECTRICAL PORTS.....</b>	<b>68</b>
11.1	CAUTIONS.....	68
11.2	DEFINITIONS.....	69
11.3	EXO TRANSLATOR.....	70

- 11.4 POWER PORT .....71
  - 11.4.1 Installing Accessories ..... 72
- 11.5 A/B INTERFACE PORTS.....73
  - 11.5.1 Installing Accessories ..... 74
- 12 OVER-THE-AIR FIRMWARE UPDATES ..... 78**
- 13 SUPPORT ..... 79**
  - 13.1 LEARN MORE.....79
  - 13.2 TECHNICAL SUPPORT.....79
- 14 SPECIFICATIONS..... 80**
  - 14.1 DETAILED SPECIFICATIONS .....80
  - 14.2 WIRELESS SPECIFICATIONS.....81
  - 14.3 GAS SENSOR SPECIFICATIONS.....82
- 15 LEGAL NOTICES AND CERTIFICATIONS ..... 83**
  - 15.1 LEGAL NOTICES.....83
  - 15.2 INTRINSICALLY SAFE CERTIFICATION .....84
  - 15.1 INMETRO CERTIFICATION.....85

## WARNINGS

- ▲ **WARNING:** The Wind Guard **MUST** be removed when the bump test or calibration is complete. Failure to remove the Wind Guard will slow down EXO's response to hazardous gases.
- ▲ **WARNING:** Only remove EXO's battery in a known safe environment with a clean atmosphere that is free of explosive gas.
- ▲ **WARNING:** The EXO quick charger is **NOT** intrinsically safe. It should only be used in a safe environment with a clean atmosphere.
- ▲ **WARNING:** **DO NOT** allow metal tools or personal items to touch the battery terminals. Touching metal or any conductive material to the battery terminals is extremely dangerous and will damage the battery.
- ▲ **WARNING:** An attached trickle charger is **ONLY** intrinsically safe when connected as described in the electrical diagrams in section 11.
- ▲ **WARNING:** Listening to EXO's siren at high volume for extended periods of time can cause permanent hearing loss. EXO's siren volume should be adjusted for use indoors and in smaller spaces. Wear appropriate ear protection during testing.
- ▲ **WARNING:** Do **NOT** power off EXO if the blue LiveResponse light is on.
- ▲ **WARNING:** EXO's sensors must only be zeroed with clean air. If a sensor is zeroed where its targeted gas levels are abnormal, the gas levels EXO displays will not be accurate. Inaccurate readings are a safety hazard.
- ▲ **WARNING:** Off-scale (overlimit) readings may indicate an explosive concentration.
- ▲ **WARNING:** Calibrations must only be performed in areas free of flammable gases.
- ▲ **WARNING:** Gas notifications will **NOT** be generated during a purge.
- ▲ **WARNING:** EXO Pump is not compatible with the following gases: Chlorine (Cl<sub>2</sub>) and Chlorine Dioxide (ClO<sub>2</sub>).
- ▲ **WARNING:** If you start the pump while operating at temperatures of -20°C (-4°F) or lower, EXO will generate a pump blocked alarm (see section 9.4) that persists until the inlet warms up and begins operating normally. In a multiple inlet sampling cycle, the inlets do not have time to warm up. For temperatures below -20°C (-4°F), use only single gas sampling.
- ▲ **WARNING:** When airplane mode is on, you cannot use the SOS latch or otherwise call for help using EXO.
- ▲ **WARNING:** When Stealth is enabled, the lights will not flash, the siren will not sound, and EXO will not indicate incoming voice calls. Blackline Safety recommends that you have an alternative channel of communication available when EXO is in Stealth.

## **blacklinesafety**

- ▲ **WARNING:** Cables attached to the power port are only intrinsically safe when properly set up with an electrical barrier.
- ▲ **WARNING:** EXO will NOT monitor when firmware is installing.

# 1 EXO OVERVIEW

EXO is Blackline Safety's cloud-connected area monitor. EXO continuously measures gas concentrations in the ambient environment at sites, facilities, and fence lines, and activates notifications when concentrations of toxic and combustible gases exceed configured setpoints.

In the event of a safety incident or gas exposure, monitoring personnel can see what has happened and communicate with workers directly through EXO via text messaging or an optional two-way voice calling feature.



There are two EXO models: EXO Pump and EXO Diffusion.

## 1.1 EXO PUMP

---

EXO Pump allows you to remotely sample up to four confined spaces or locations.

EXO Pump has a manual calibration inlet that requires a fixed flow regulator to function correctly. It also has four pump inlets that can sample air from remote areas using internal pumps and external tubes.

### 1.1.1 IN THE BOX

EXO Pump comes with the following components:

- EXO Pump area gas monitor
- 1 m (3 ft) of tube fitted with a quick connect coupling insert
- Quick charger with battery pack hex key
- Pre-installed multi-gas cartridge



# blacklinesafety

- Pre-installed cellular connection module
- Pre-installed gas inlet module (one of two)
- Optional pre-installed satellite connection module
- Certification and support card

## 1.1.2 HARDWARE DETAILS



Figure 1-1: EXO Pump Front



Figure 1-2: EXO Pump Back



Figure 1-3: EXO Pump Bottom



Figure 1-4: EXO Pump Right Side

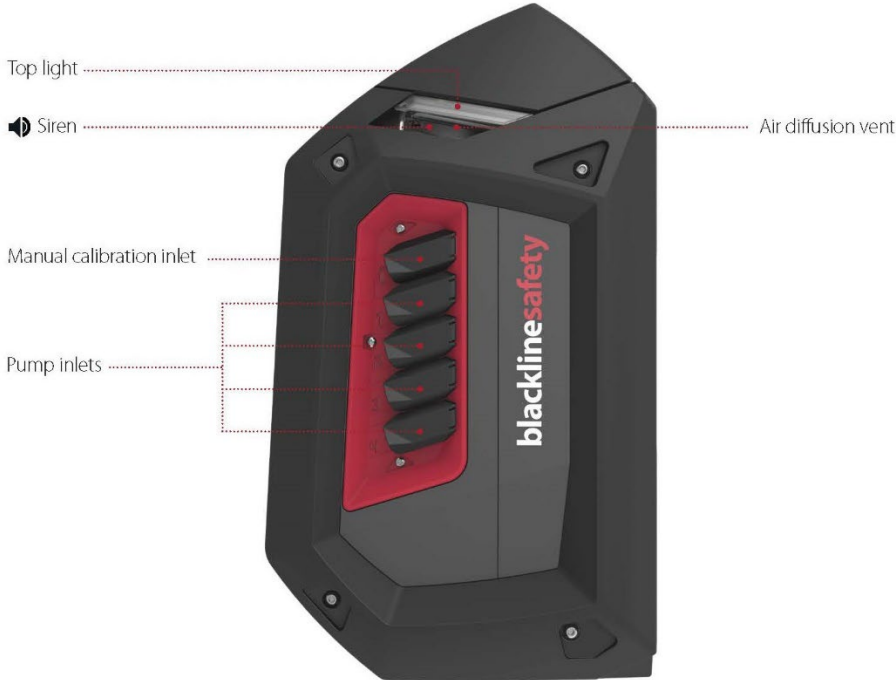

Figure 1-5: EXO Pump Left Side

## 1.2 EXO DIFFUSION

---

EXO Diffusion allows you to effectively monitor and measure ambient gas concentrations.

EXO Diffusion has a manual calibration inlet that requires a fixed flow regulator to function correctly.

### 1.2.1 IN THE BOX

EXO Diffusion comes with the following components:

- EXO Diffusion safety and area gas monitor
- Wind Guard
- 1m (3 ft) of tube fitted with a quick connect coupling insert
- Quick charger with battery pack hex key
- Pre-installed multi-gas cartridge
- Pre-installed cellular connection module
- Pre-installed gas inlet module (one of two)
- Optional pre-installed satellite connection module
- Certification and support card

1.2.2 HARDWARE DETAILS

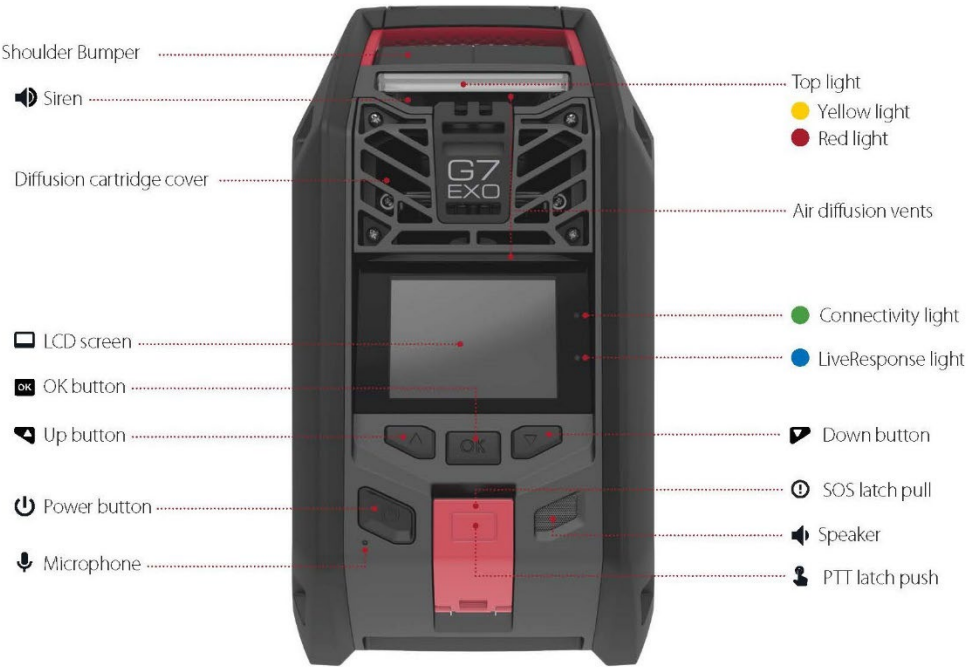

Figure 1-6: EXO Diffusion Front



Figure 1-7: EXO Diffusion Back



Figure 1-8: EXO Diffusion Bottom



Figure 1-9: EXO Diffusion Left Side



Figure 1-10: EXO Diffusion Right Side

### 1.2.3 WIND GUARD

When bump testing or calibrating EXO Diffusion in windy conditions, the Wind Guard is required to help regulate the flow and concentration of gas delivered to the sensors.

#### To use the Wind Guard:

1. Position the Wind Guard in front of EXO with the narrow ends on top, as shown below.
2. Slide the Wind Guard into the front air diffusion vents (underneath the Top Lights). When the Wind Guard is in the proper position, the two clamps will lock.
3. Bump test or calibrate as usual.
4. When bump test or calibration is complete, immediately remove the Wind Guard and store it in a clean, dry environment for later use.



**▲ WARNING:** The Wind Guard **MUST** be removed when the bump test or calibration is complete. Failure to remove the Wind Guard will slow down EXO's response to hazardous gases.

## 1.3 BLACKLINE SAFETY SERVICE PLANS

---

EXO comes with basic system access, which allows EXO to connect to Blackline Live.

Blackline Safety implementations are tailored to your needs and organization, and are based on your expertise, staffing, and business goals.

There are various service plans available to suit your organization's needs. For more information, contact your Customer Relationship Manager (CRM).

## 1.4 BLACKLINE SAFETY SERVICES

---

### 1.4.1 BLACKLINE SAFETY MONITORING

Depending on your needs and requirements, various service plan options are available for EXO, including 24/7 live safety monitoring by Blackline Safety.

Contact your organization's safety professional for more information regarding the details of your service plan.

For more information, please see [Blackline 24/7 Live Monitoring](#).



## 1.4.2 BLACKLINE LIVE

Blackline Live monitors your Blackline Safety devices and allows you to access reports and, depending on your plan, business analytics insights.

Blackline Live also allows you to create and customize configuration profiles that determine how a device, or a group of devices, operates in the field.

For more information, please see [Blackline Live](#).

## 1.4.3 BLACKLINE ANALYTICS

If enabled by your service plan, Blackline Analytics allows you to review data collected from your device fleet to make decisions, follow up with your team, and ensure everything is running smoothly. Blackline Analytics provides a variety of pre-defined reports and filters to explore your data.

For more information, please see [Blackline Analytics](#).

## 1.5 COMMUNICATION INTERVALS

---

The following table describes the default communication frequency to Blackline Live for each connection module:

	Normal Operation	When EXO is in Motion	During a High Urgency Event
Cellular	30 min	30 seconds	Immediately
Satellite	2 hr	30 min	Immediately

**NOTE:** If your configuration profile has Gas Alert Countdown enabled, communication to monitoring personnel will be delayed by 30 seconds during high urgency gas events.

## 1.6 CONNECTION MODULES

---

A connection module links EXO to Blackline Live using a cellular network or the Iridium satellite network.

EXO will first try to connect to Blackline Live with the built-in cellular connection module. If cellular coverage is not available and an optional satellite connection module is installed, EXO will try to connect to Blackline Live through the Iridium satellite network. See sections 3.4 and 4.3 for more information on connectivity.

### 1.6.1 CELLULAR CONNECTION MODULE

This module works with 2G/4G networks in Europe, and 3G/4G networks in North America to connect EXO to Blackline Live. Cellular series are available in over 100 countries, supporting over 200 cellular networks. This module is built into every EXO.

### 1.6.2 SATELLITE CONNECTION MODULE

When EXO is not in an area with cellular coverage, this module works with the Iridium satellite network to connect EXO to Blackline Live. This module can be pre-installed in EXO, or it can be purchased as an upgrade for EXOs in the field. For installation instructions, refer to the [EXO Satellite Installation Guide](#).

**NOTE:** Two-way voice capabilities and push-to-talk (PTT) are not available when connected via satellite.

**NOTE:** You may experience a reduction in data collection while using the satellite module.

#### Changing the connection type

By default, EXO connects to the cellular network.

To change from satellite to cellular or vice versa:

1. Open the main EXO menu and use the arrows to select **Communication**.
2. Select the connection module you want to use.

**NOTE:** The Communication menu option is only available if a satellite module is installed.

You can tell which connection type EXO is using by the connectivity icon displayed on the EXO main screen. See section 4.3 for more information about connectivity icons.

### 1.6.3 DETERMINING IF A SATELLITE MODULE IS INSTALLED

If you are unsure if EXO has a satellite connection module installed, check the window behind the battery pack.

You can also find this information on the device:

1. Press OK to open the main menu.
2. Select **Advanced**.
3. Select **Comm info**.



Figure 1-11: Satellite Connection not Installed



Figure 1-12: Satellite Connection Installed

## 2 CARTRIDGES

### 2.1 CARTRIDGE OPTIONS

---

EXO can only use multi-gas (diffusion) cartridges, which can be configured to detect up to four gases, or five gases when using a dual CO and H<sub>2</sub>S (COSH) sensor.

**NOTE:** All Blackline Safety cartridges are intrinsically safe. This means EXO's cartridges can be changed in potentially hazardous zones.



## 2.2 CHANGING CARTRIDGES

---

### To remove a cartridge:

1. Power off EXO.
2. Unscrew the four cartridge cover screws.  
**NOTE:** These are captive screws and should stay attached to the cartridge cover.

3. Pull forward on the cartridge cover to remove. Set aside.
4. Pull the cartridge out of the cartridge slot.



### To insert a cartridge:

1. Orient the cartridge so the sensors are facing down.
2. Push the cartridge into the cartridge slot.
3. Replace cartridge cover.
4. Tighten the screws.

**NOTE:** The screws should be snug, but not over-tight.

## 2.3 SENSOR CONTAMINANTS

---

Gas sensors are susceptible to contamination by a variety of common chemicals, reducing or eliminating their effectiveness.

For details on preventing sensor contamination, see [Cleaning Devices and Accessories](#) on the Blackline Support site.

## 2.4 CARTRIDGES AND EXTREME WEATHER

---

EXO operates optimally in the range of -20°C to 50°C (-4°F to 122°F). For best practices operating EXO outside that range, see [Operating Devices in Extreme Weather](#) on the Blackline Support site.

## Electrochemical sensors

At temperatures below -20°C (-4°F), the sensor electrolyte inside CO, H<sub>2</sub>S, and other electrochemical sensors can freeze over time, reducing the ability of the sensor to give a meaningful output. Storing EXO in a warm and humid (60% relative humidity) environment when not in use will help keep electrochemical sensors running longer.

Shocking an electrochemical sensor from room temperature to extreme cold and vice versa can also cause temporary drifts in sensor readings. These readings typically resolve in less than 60 seconds.

## Infrared (IR) LEL sensors

Sudden temperature and humidity changes may cause condensation within the LEL-IR sensor, which can affect its optics and trigger a temporary baseline drift. Typically, these readings last less than 60 seconds, after which point the readings will recover and EXO will function as normal.

Shocking the IR sensor from room temperature to an extremely cold environment can cause a temporary baseline drift, typically less than 10% LEL. If this drift persists you can manually zero the sensor in the cold environment.

Shocking the IR sensor from an extremely cold environment to room temperature can cause a temporary baseline drift, sometimes reaching overlimit.

## 3 SETUP

### 3.1 LOCATION

---

EXO finds its location in two ways: through satellite-based positioning or by scanning for Blackline Location Beacons.

**NOTE:** A defined location helps emergency response teams know where to respond. However, EXO does not need a determined location to function as a safety monitor or gas detector.

#### Satellite-based positioning (GPS)

EXO can use GPS, QZSS, Galileo, and BeiDou satellite constellations to determine its location. Satellite-based positioning works best when the monitor is outside with a clear view of the sky. If EXO is within a Location Beacon's signal radius and satellite-based positioning is also available, the one with the strongest signal will be used.

## Location Beacons

When within a beacon's signal radius, EXO will see the beacon and send the beacon's ID to Blackline Live. EXO's location will be recorded as the beacon's pre-defined location. If EXO sees multiple beacons, it will be associated with the beacon with the strongest signal. If beacons and satellite-based positioning are both available, the one with the strongest signal will be used. This is configurable in Blackline Live. Contact your organization's factory personnel for more information regarding configurations.

### 3.1.1 DETERMINING LOCATION

EXO performs best when placed strategically within the area you wish to monitor. When placing EXO, consider the following:

#### Positioning

- Keep EXO upright.
- Keep EXO accessible for regular interactions like bump tests and messages.
- Do not hang EXO by its handle. For hanging instructions, refer to the [EXO Hanging Mount Guide](#).

#### Environment

- Keep EXO's electrical ports and gas inlets covered when not in use.
- Do not place EXO in water.
- Consider wind direction and air flow.

#### Connectivity

- If connecting to Blackline Live through a satellite network, EXO needs to be outdoors with a clear view of the sky.
- If connecting to Blackline Live through a cellular network, EXO may struggle to find connection indoors or in areas of weaker cellular reception.

## 3.2 MOUNTING

---

The base of the EXO is fitted with a mounting plate with two sizes of threaded mounting points. The use of all mounting points is not required to mount EXO. Select the appropriate mounting points for your application.

**Type A Mounting Point**

A single mounting point threaded 5/8 in – 11 UNC with a maximum depth of 3/4 in or 19 mm.

**Type B Mounting Point**

Five mounting points that are M6 threaded with a maximum depth of depth of 5/8 in or 16 mm.

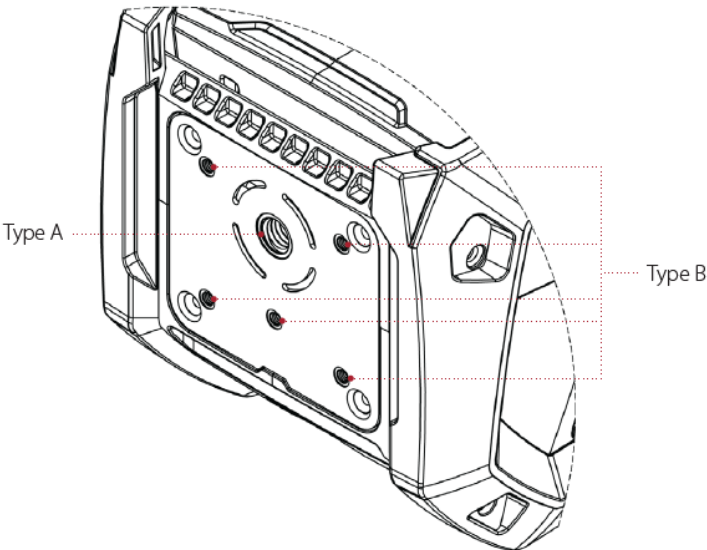

### 3.2.1 MOUNTING POINT LAYOUT

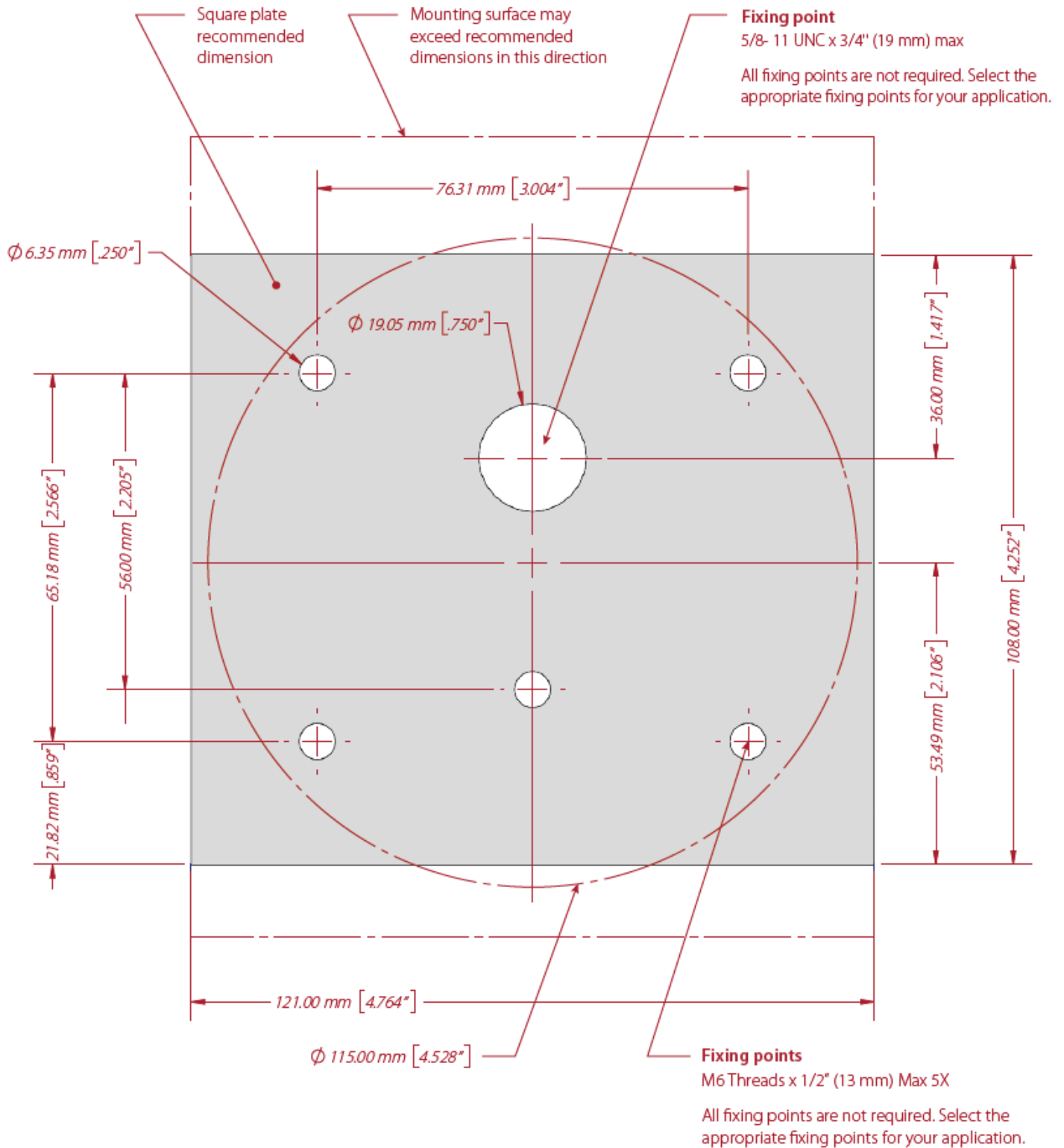



## 3.3 SETUP WIZARD

---

The setup wizard is an optional test that tells you EXO is operating correctly and fully. It establishes that EXO can determine its location, can connect to Blackline Live, and is vertical.

EXO will continue to monitor for gas in the area during the setup wizard test. Low urgency notifications, an SOS latch pull, or dangerous gas levels override the setup wizard.

### To run from start-up:

1. Power on EXO. EXO will go through the start-up sequence.
2. At the end of the start-up sequence a prompt to start the setup wizard will display on the screen.

If no selection is made after 15 seconds, the prompt screen will time out and EXO will automatically go to the main gas detection screen without running the setup wizard.

If you choose to run the setup wizard, EXO will execute the setup automatically. This should only take a few minutes.

### To run from the main menu:

1. Press the OK button to enter the main menu.
2. Select **Setup wizard**. EXO will execute the setup automatically.

### If setup wizard is successful:

EXO will let you know with a success sound and the screen will display “ready for use.”

1. Select **Exit** to go to the main gas detection screen.

### If setup wizard is unsuccessful:

EXO will let you know with a failure sound and the screen will display “Insufficient”. One of the three following reasons for the failure will be listed on the screen with a red X:

- EXO could not determine its location.
  - EXO could not connect to Blackline Live.
  - EXO is not vertical.
1. Address each item on the list, then select **Retry** to run the setup wizard again.
  2. Select **Exit** to skip the setup wizard and go to the main gas detection screen.

## 3.4 CONNECTIVITY LIGHT

---

EXO lets you know its connection status through the green connectivity light.

### Blinking green light

A blinking connectivity light indicates EXO is trying to connect to Blackline Live. EXO will continue to monitor the area, although monitoring personnel cannot receive communications while the light is blinking. Data collected by EXO while the green connectivity light is blinking will be sent when EXO connects to Blackline Live. This includes low urgency and high urgency notifications, location, messages, etc.

### Solid green light

A solid connectivity light indicates EXO is connected to Blackline Live and all data collected by EXO is being transmitted to Blackline Live. Monitoring personnel will receive and respond to high urgency notifications while this light is solid.

### Connection lost

If EXO loses connection to Blackline Live, an operational notification will be triggered after a configurable length of time. If EXO reconnects to Blackline Live within this time limit, no notification will be triggered.

See sections 1.6 and 4.3 for more information on connectivity.

## 4 OPERATION

### 4.1 EXO PUSH BUTTONS

---

Interacting with EXO is easy with its high-visibility, backlit LCD display, three-button menu system and SOS latch.



#### OK button

Press the OK button to enter the main menu on the LCD screen. Press the OK button to confirm a menu selection.



### Up and down buttons

Use the up and down buttons to navigate options. Press and hold both buttons simultaneously to acknowledge and mute a low urgency or high urgency notification.



### SOS latch pull

Pull the SOS latch to call for help when emergency assistance is required. See section 7.2 for more information.



### Latch push (optional)

Push and hold the SOS latch to record a push-to-talk (PTT) message. Release the latch to send the message to devices on the same channel. See section 10.3 for more information.

## 4.2 POWERING ON EXO

Powering on EXO initiates the device's start-up sequence.

To power on EXO:

1. Press and hold the power button for two seconds. You will know when EXO has finished its start-up sequence when it completes the following stages:
  - EXO will sound a chime, signaling it is powering on.
  - The top lights will flash.
  - The screen will display the active features on EXO.
  - The green connectivity light will stop flashing and become solid, indicating EXO is connected to Blackline Live.

**NOTE:** if you see an **O<sub>2</sub> stabilizing** message on EXO's screen, it means EXO is not monitoring. Stabilization typically takes approximately 10 seconds. However, if EXO has been powered

off for a significant period, it can take up to 20 minutes for the O<sub>2</sub> sensor to stabilize. If this message persists, contact your organization’s safety professional.

### 4.2.1 POWERING OFF EXO

**NOTE:** If the maintenance code is enabled, you will be required to input the correct code to unlock EXO before powering off. See section 4.6 for more information about the maintenance code.

To power off EXO:

1. Press and hold the power button for three seconds. You will know EXO has finished powering off when it completes the following stages:
  - EXO will sound a chime signaling it is powering off.
  - The screen will go into EXO’s shutdown sequence.
  - When all the lights and sounds have stopped, EXO is powered off and disconnected from Blackline Live.

**NOTE:** Make sure all high urgency notifications have been resolved before powering off. Do NOT power off EXO if the blue LiveResponse light is on. This may mean waiting for monitoring personnel to contact you through EXO. See section 7 for more information on high urgency notifications.

## 4.3 EXO LCD DISPLAY

---

### 4.3.1 MAIN MENU

To enter the main menu, press the OK button while on the Gas status screen. The main menu contains additional features and device information available to EXO users.

### 4.3.2 GAS STATUS SCREEN

EXO’s main screen is the Gas status screen. EXO’s multi-gas cartridge sensor configuration will determine the layout of this screen.

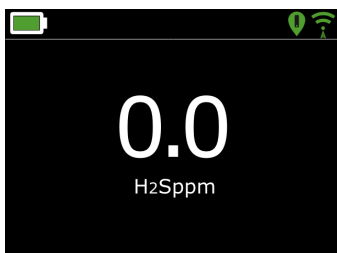

One gas

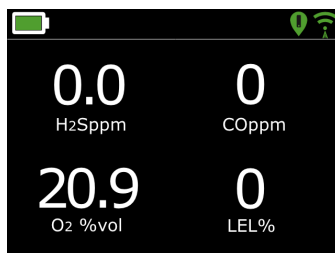

Four gases

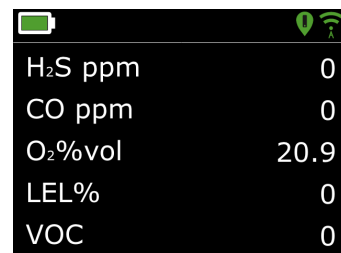

Five gases





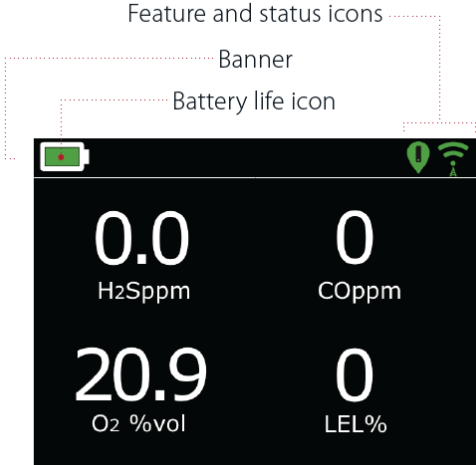

### 4.3.3 BANNER

The banner at the top of the Gas status screen is where you will find more information about low urgency and high urgency notifications, battery life, location, and connectivity.



### Battery life icon

The battery icon in the top bar of the screen shows how much charge the battery has. See section 4.4 for more information regarding the battery pack.

-  Lightning bolt: Battery charging
-  5 bars: 81% to 100%
-  4 bars: 61% to 80%
-  3 bars: 41% to 60%
-  2 bars: 21% to 40%
-  1 bar: 1% to 20%
-  Red bar: Low battery

**NOTE:** By default, a “Low battery” message will be displayed in the banner and the battery icon will become red when the battery’s power drops below 10%. This threshold is configurable in Blackline Live.

## Location icon

Only one location icon will be displayed at a time. See section 3.1 for more information regarding EXO's location.



### Beacon

Displayed when a beacon signal is present



### Satellite positioning (GPS)

Displayed when no beacon signal is present and satellite positioning is possible



### None

Displayed when there are no beacon signals and satellite positioning is not possible

## Connectivity icon

Only one connectivity icon will be shown at a time. See sections 1.6 and 3.4 for more information about connectivity.



### Cellular

Displayed when EXO is connected to Blackline Live through a cellular network



### Satellite

Displayed when EXO is connected to Blackline Live through satellite



### None

Displayed when EXO is NOT connected to Blackline Live

## 4.4 EXO BATTERY

---

All EXOs are shipped with a pre-installed battery pack and a quick charger. The battery (labeled ACC-G7EXO-BATXX) comes in two models.

1. Standard (144 Ah): ACC-G7EXO-BAT
2. Lightweight (72 Ah): ACC-G7EXO-BAT-LT

### 4.4.1 BATTERY LIFE

The standard battery pack can power EXO for over 100 days, and the lightweight version for over 50 days. Battery life will vary depending on device configurations, low urgency and high urgency notification response, operating temperature, sensor types, and pump usage. In operational temperatures below -20°C (-4°F), the battery pack's runtime will drop significantly. See section 2.4 for more information about running EXO in cold temperatures.

### 4.4.2 BATTERY STORAGE

For long-term storage, Blackline recommends storing the battery at 20°C (68°F).

### 4.4.3 BATTERY GAUGE

Press and hold the battery gauge button on the battery pack to show the remaining battery charge.

**NOTE:** A dimmed bar indicates that the battery is in the lower half of the bar's percentage range.

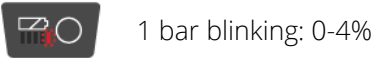
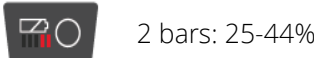
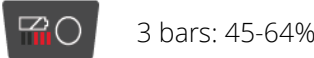
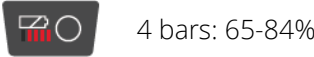

#### Battery gauge while charging

The battery gauge will automatically light up and remain lit while the battery pack is charging. The gauge will display the current charge of the battery pack as described above. When the battery reaches 100%, it will stop charging and the gauge's light will turn off.

## 4.5 CHARGING EXO

### 4.5.1 USING THE QUICK CHARGER

The EXO quick charger connects directly to the EXO battery and charges it overnight.

- ▲ **WARNING:** Only remove EXO's battery in a known safe environment with a clean atmosphere that is free of explosive gas.
- ▲ **WARNING:** The EXO quick charger is NOT intrinsically safe. It should only be used in a safe environment with a clean atmosphere.
- ▲ **WARNING:** DO NOT allow metal tools or personal items to touch the battery terminals. Touching metal or any conductive material to the battery terminals is extremely dangerous and will damage the battery.

#### Operating temperature for quick charger

The quick charger's ideal operating temperature is 22°C (72°F) but it can be used between 5°C and 40°C (41°F to 104°F) without any adverse effects.

#### To remove the battery:

1. Power off EXO.
2. Ensure EXO is in a safe environment with a clean atmosphere.
3. Loosen the two self-retaining screws at the top of the battery on the back of EXO.

**NOTE:** This requires a 4 mm hex key (included with EXO).

4. Pull the top of the battery away from EXO.

**NOTE:** When EXO is vertical, the battery will lean away from EXO, allowing you to grip and remove the battery.



Battery removal detail



To charge the battery using the quick charger:

1. Lift the rubber flap at the top of the battery pack to expose the charging port.
2. Plug the quick charger into the battery's charging port.
3. Plug the quick charger into an outlet.
4. Turn the charger's power switch on. Charging may take up to 12 hours.

**NOTE:** The battery pack is fully charged when the red light on the charger turns green.

5. When fully charged, remove the quick charger from the charging port.
6. Replace the rubber flap to cover the charging port.

To insert the battery:

1. Ensure EXO is in a safe environment with a clean atmosphere.
2. Hold the battery at a 45-degree angle with the bottom pointing towards EXO.
3. Place the battery bottom first into EXO's battery slot.
4. Push the top of the battery towards EXO until it sits flush.
5. Tighten the two screws at the top of the battery.

**NOTE:** The screws should be snug, but not over-tight.

## 4.5.2 TRICKLE CHARGER



Power port detail

You may choose to buy an EXO Trickle Charger Kit from Blackline Safety. This kit connects EXO directly to a power source through the power port eliminating the need to power down and remove EXO from the field to charge the battery pack. See section 11.3 for more information about the power port.

**▲ WARNING:** An attached trickle charger is ONLY intrinsically safe when connected as described in the electrical diagrams in section 11.

## 4.6 MAINTENANCE CODE

---

EXO features an optional maintenance code function to prevent unauthorized individuals from changing the settings when the device is unmanned. EXO's entire menu, device power-down and volume change actions are locked when a maintenance code is enabled. Entering the code will allow you to access locked features.

Enabling the maintenance code and setting the four-digit number passcode is done using the EXO configuration profile page available in Blackline Live.



When the device is locked, a lock icon will be shown in the gas status screen banner. Pressing any button while EXO is locked will display the maintenance code entry screen.

To unlock EXO:

1. Press any button to display the maintenance code entry screen. You will be prompted to enter a four-digit number.
2. Use the up and down buttons to select a number for the current digit.
3. Press OK to move to the next digit.
4. After selecting the final digit, press OK to enter the entire code.

If successful, the entered code will become green, and the Gas status screen will open.

If unsuccessful, the entered code will become red.

You can either select **Retry** to enter another code, or **Back** to return to the locked Gas status screen.

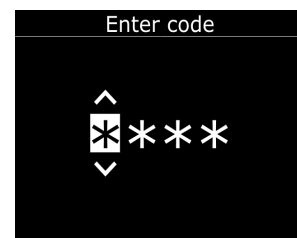

## 4.7 ALARM TEST

---

EXO's alarm test is an audio/visual assessment used to ensure the siren, speaker, LED lights and microphones are operating correctly. The top lights will flash, and the notification pitch will increase. The volume of alarm test sounds cannot be adjusted.

An alarm test is run at the following times:

- As part of the start-up sequence
- Before all bump tests
- Before each calibration

If EXO detects a problem while running the alarm test, the full test will immediately be attempted two more times. If EXO still detects a problem after the third attempt, the failed alarm test results will be recorded and sent to Blackline Live.

**NOTE:** Muffling the speaker during an alarm test will result in a failure. An environment that is too loud will also result in a failed alarm test.

## 4.8 SIREN

---

The siren is used to inform you of the following:

- Operational notifications
- Low urgency notifications
- High urgency notifications
- Sensor errors

For EXO to function effectively as an area gas monitor, the siren must be loud enough to be heard over all environmental noise. EXO's siren volume, measured at 6 in. (152.4 mm) from the device, is:

- High: 98dB
- Medium: 82dB
- Low: 72dB

To adjust EXO's siren volume:

1. Press OK to enter the main menu.
2. Select **Settings**.
3. Select **Siren volume**.
4. Use the up and down buttons to select the desired volume.

▲ **WARNING:** Listening to EXO's siren at high volume for extended periods of time can cause permanent hearing loss. EXO's siren volume should be adjusted for use indoors and in smaller spaces. Wear appropriate ear protection during testing.



## 4.9 SPEAKER

---

The speaker is used to inform you of the following:

- Notifications triggered by incoming two-way messages
- Connection lost notifications
- Two-way voice calls
- Push-to-talk (PTT) messages
- Shutdown sounds

**NOTE:** EXO's speaker volume cannot be adjusted.

## 5 OPERATIONAL NOTIFICATIONS

Operational notifications are used to communicate events that are triggered by routine and expected device operations. Operational notifications provide you with information or prompt you to take action. An operational notification includes yellow flashing lights and sound, and an on-screen message specific to the event.

The settings for operational notifications are configurable in Blackline Live to best fit your needs. Contact your safety supervisor to learn more about how EXO's features are configured.

Operational notifications are local to your device and will not notify monitoring personnel if your device is monitored.

Operational notifications repeat until you acknowledge them.

### 5.1 ACKNOWLEDGING OPERATIONAL NOTIFICATIONS

---

To acknowledge an operational notification:

1. Read EXO's screen.
2. Press and hold the up and down arrow buttons at the same time to mute the notification and acknowledge the banner message.
3. A safety supervisor or someone with proper training for EXO should perform specific tests or procedures to address the issue (e.g., calibrating the device).



## 5.2 OPERATIONAL NOTIFICATION TYPES

---

Operational notifications are:

- Low battery
- Lost connection
- Bump test due (Optional)
- Calibration due (Optional)
- Timer done

### Low battery

The low battery notification interval is configurable (10%-70%) by your Blackline Live administrator. Your Blackline Live administrator can also mute the notification sound and LED patterns associated with this notification.

The low battery notification is activated when EXO detects that it is operating below the configured low battery threshold.



### Lost connection

The lost connection interval is configurable (min.) by your Blackline Live administrator.

The lost connection notification is activated when EXO fails to connect with Blackline Live for the configured time interval (e.g., 5 min).



### Bump test due (Optional)

The bump test due notification interval is configurable by your Blackline Live administrator. Your Blackline Live administrator can also mute the bump test due notification sound and LED patterns.

The bump test due notification is activated when EXO is due for a bump test within the interval (hours or days) configured in Blackline Live.

### Calibration due (Optional)

The calibration due notification interval is configurable by your Blackline Live administrator. Your Blackline Live administrator can also mute the calibration due notification sound and LED patterns.

The calibration due notification is activated when G7 is due for calibration within the interval (hours or days) configured in Blackline Live.

### Timer done

The timer done notification is activated when the EXO timer counts down to zero.

## 6 LOW URGENCY NOTIFICATIONS

Low urgency notifications are used to communicate events that are triggered by an unexpected condition that could pose a safety risk if not addressed in a timely manner. A low urgency notification includes yellow flashing lights and sound, and an on-screen message specific to the event.

The settings for low urgency notifications are configurable in Blackline Live to best fit your needs. Contact your safety supervisor to learn more about how EXO's features are configured.

Low urgency notifications are local to your device and will not notify monitoring personnel if your device is monitored. Event data related to low urgency notifications is uploaded to Blackline Live during your device's next synchronization.

Low urgency notifications repeat until you acknowledge them.

## 6.1 ACKNOWLEDGING LOW URGENCY NOTIFICATIONS

---

To acknowledge a low urgency notification:

**IMPORTANT:** Always follow your company's safety protocol for responding to low urgency notifications. Blackline recommends leaving the area.

1. Read EXO's screen and inform personnel if they need to leave the area.
2. Press and hold the up and down arrow buttons at the same time to mute the notification and acknowledge the banner message.

**NOTE:** For continuous gas exposure, EXO will unmute itself after two minutes if gas levels have not returned to normal.



## 6.2 LOW URGENCY NOTIFICATION TYPES

---

Low urgency notifications are:

- Incoming message
- Two-way voice call
- Errors (hardware, cartridge, sensor, firmware)
- Low gas
- Sensor under limit
- Pump blocked
- Tumble (Optional)
- AlertLink

### Incoming message

EXO can receive messages from monitoring personnel via Blackline Live. Messages are available in your device's Message inbox. See section 10.1 for more information on messages.

The incoming message notification is activated as soon as your device receives a message.



## Two-way voice call

If EXO has the two-way voice call feature enabled and is in cellular coverage, it can receive two-way voice calls from monitoring personnel, such as during a response to high urgency notifications.

You cannot initiate or end voice calls from EXO. Voice calls are automatically answered by EXO. See section 10.2 for more information on two-way voice calls.



## Errors (hardware, cartridge, sensor, firmware)

The error notification is activated when EXO experiences an error (e.g., your gas sensor stops working).

**IMPORTANT:** Following an error notification, Blackline recommends that you power off and restart your device. If the error persists, try updating the firmware (see section 12). If the error does not clear, contact Blackline [Technical Support](#).

## Low gas

The low gas threshold is configurable by your Blackline administrator.

The low gas notification is activated when gas levels reach the configured threshold for your device.

**NOTE:** An EXO with an O<sub>2</sub> sensor will notify you in both oxygen-deficient and oxygen-enriched atmospheres. An oxygen-deficient atmosphere poses a risk of insufficient oxygen for breathing. An oxygen-enriched atmosphere presents an increased risk of explosion.

**IMPORTANT:** You can choose to mute the sound portion of a low gas notification, but the lights will stay active.

Persistent lights and recurring sounds are there to encourage you to leave, and to help emergency responders to locate you if you lose consciousness or are unable to remove yourself from the area.

After acknowledging a low gas notification, move to an area where gas is not present. If you do not leave the area and gas levels remain above the low threshold, the low gas notification will reactivate after 2 minutes.



## Sensor under limit

The sensor under limit (UL) notification is activated when your device detects a UL gas event.

**IMPORTANT:** Following a UL notification, no peak is logged because the UL event type is closely related to a device or sensor error. To resolve the UL event, Blackline Safety recommends that you calibrate your device. For more information on calibration, refer to section 8.2.

## Pump blocked

The pump blocked notification is activated when your pump inlet is blocked.

## Tumble alarm (Optional)

When tumble alarm is enabled, EXO will trigger a low urgency notification if it is knocked over. In addition to lights and sounds on the device, the event can be seen in the device history and, if a notification profile has been configured, a message will be sent to identified contacts.

## AlertLink

AlertLink notifications let you know that another G7c, G7x, or EXO device within the configured proximity radius is experiencing a high urgency event. AlertLink notifications trigger a unique light and sound pattern.

**NOTE:** AlertLink is only available for self-monitored or Blackline-monitored organizations.

Your EXO will receive a message at the time of the triggering event, which includes the alert type, the assigned user of the origin device, the origin device type, other device information, and gas type when applicable.

When the AlertLink notification is activated, proceed based on your company's safety protocol. The notification can be configured to persist for a maximum of 90 minutes until it is manually acknowledged on the device or to clear automatically after pre-set period of time (15 minute default). The notification can also be cleared remotely by monitoring personnel in Blackline Live.

AlertLink functionality and the proximity radius can be configured in Blackline Live by your company's Blackline Live administrator. You can also exclude EXO from receiving AlertLink notifications in Blackline Live. For more information, refer to the [Blackline Live Technical User Manual](#).

## 7 HIGH URGENCY NOTIFICATIONS

High urgency notifications communicate events that require your immediate attention and action. A high urgency notification includes red flashing lights, sound, and an on-screen message specific to the event.

If your organization is monitored, high urgency notifications are immediately communicated to monitoring personnel and automatically generate an alert in Blackline Live. If gas levels return to normal or you manually mute the sound, this does NOT cancel the notification sent to monitoring personnel.

**NOTE:** If your configuration profile has Gas Alert Countdown enabled, communication to monitoring personnel will be delayed by 30 seconds.

### 7.1 ACKNOWLEDGING HIGH URGENCY NOTIFICATIONS

---

To acknowledge a high urgency notification:

1. Immediately evacuate the area and follow your company's emergency safety protocol.
2. If you know the area is safe and your company's protocol allows you to stay in the area:
  - a. Read EXO's screen.
  - b. Press and hold the up and down buttons at the same time to mute the notification and acknowledge the banner message.

**NOTE:** For continuous gas exposure, EXO will unmute itself after one minute if detected gas levels have not returned to normal.



### 7.2 HIGH URGENCY NOTIFICATION TYPES

---

High urgency notifications are:

- High gas
- Overlimit (OL)
- SOS alert

## High gas

The high gas notification is activated when EXO detects gas levels above the high gas concentration threshold configured by your Blackline Live administrator.

**NOTE:** A device equipped with an O<sub>2</sub> sensor will activate high gas notifications in both oxygen-deficient and oxygen-enriched environments.

When you acknowledge the high gas notification, your device's banner and lights will reflect the high gas status until the gas conditions dissipate and the high gas event is resolved.

If gas levels remain above the high threshold for more than 60 seconds, the high gas notification will retrigger with lights and sound until the high gas event is resolved.

EXO is equipped with a high gas countdown timer that is configurable (enabled/disabled) by your Blackline Live administrator. Enabling the countdown timer can help reduce the frequency of false high gas event notifications. If enabled, the countdown timer will delay connecting to Blackline Live for 30 seconds.

If AlertLink is enabled, G7c and EXO devices within the configured proximity radius of your device at the time of the triggering event will receive a low urgency notification and a message with the alert details.

**NOTE:** You can exclude EXO from receiving AlertLink messages.

Following the high gas notification, the logged peak value of the high gas event is displayed on the Gas options screen. The device will show the peak value recorded until a new peak is reached, or the peak value is reset during a power cycle of the device.

## Over limit (OL)

The sensor over limit (OL) notification is activated when EXO detects that the gas reading has exceeded the range of its sensor.

When you acknowledge the OL notification, EXO's banner and lights will reflect the high gas status until the gas conditions dissipate and the OL event is resolved.

If AlertLink is enabled, G7c and EXO devices within the configured proximity radius of your device at the time of the triggering event will receive a low urgency notification and a message with the alert details.

**NOTE:** EXO may be excluded from receiving AlertLink messages.

Following the OL notification, the OL event is displayed on the Gas options screen. The device will show the peak value recorded until a new peak is reached, or the peak value is reset during a power cycle of the device.

## SOS alert

If you require assistance, you can manually send an SOS to monitoring personnel and request immediate help to your location by pulling the SOS latch.

When you acknowledge the notification, your device's banner and lights will reflect the SOS status until the SOS event is resolved.

**NOTE:** The SOS alert notification is configurable by your Blackline Live administrator.

If AlertLink is enabled, G7c and EXO devices within the configured proximity radius of your device at the time of the triggering event will receive a low urgency notification and a message with the alert details.

**NOTE:** EXO may be excluded from receiving AlertLink messages.



## 7.3 LIVE RESPONSE

The blue LiveResponse light lets you know that remote monitoring personnel are responding to an alert by following your team's emergency protocol. When monitoring personnel have confirmed the safety of everyone in the area and resolved the alert, the blue LiveResponse light will shut off.

Depending on your team's response protocol, an EXO with voice enabled can also be contacted by monitoring personnel to create a two-way conversation between the end user and the monitoring agent responding to the alert.

**▲ WARNING:** Do NOT power off EXO if the blue LiveResponse light is on.



# 8 GAS DETECTION

## 8.1 BUMP TEST

Bump testing verifies that your device's gas sensors and notification indicators (lights, siren, speaker, and microphone) are functioning correctly. During a bump test, you apply a known

concentration and amount of gas to confirm the sensors will trigger a notification in the event of gas exposure.

EXO automatically communicates the data collected from each bump test to Blackline Live when it is connected to the cellular or satellite network.

## Bump test schedule

The bump test schedule can be configured to match your company's safety policy. These changes are made in the configuration profile in Blackline Live.

Blackline recommends that your bump test interval not exceed 30 days. Where site or regulatory requirements are more stringent, Blackline recommends the more stringent requirements apply.

The bump test results in either a pass or fail. Exiting the bump test before all sensors have been tested will result in a fail.

On start-up, EXO will display when the next bump test is due. By default, an overdue bump test will cause a reminder message to display in the banner of the Gas status screen. The bump test overdue reminder is configurable in Blackline Live.

## Gas cylinders

Sensors can be manually bump tested at the same time using one gas cylinder with a multi-gas mixture, or individually using multiple gas cylinders. If using multiple cylinders, the manual bump test procedure will need to be repeated for each cylinder. In step 6 of the manual bump test procedure (section 8.1.1), ensure all the gas sensors that correspond to the attached cylinder's gas mixture are selected. The gas concentration of the connected gas cylinder should match the gas concentration listed in EXO's calibration gas configuration in Blackline Live.

**NOTE:** Some cartridges require you to bump test sensors in a specific order due to gas sensor cross sensitivity. Refer to [G7 and EXO Gas Sensor Bump Testing and Calibration Order](#) on the Blackline Support site for more information.

### 8.1.1 MANUAL BUMP TEST

To perform a manual bump test, you will need:

- A cylinder or cylinders containing the appropriate gas(es)
- A 0.5 LPM (or 1 LPM for Cl<sub>2</sub>, HCN, NO<sub>2</sub>, NH<sub>3</sub>, SO<sub>2</sub>, or H<sub>2</sub>S) fixed flow regulator attached to the cylinder(s)
- A tube fitted with a quick connect coupling insert

**NOTE:** If you are bump testing EXO Diffusion in a windy environment, you must use the wind guard. See section 1.2.3 for more information on using the wind guard.

**To perform a manual bump test:**

1. Ensure EXO is in clean air.
2. Press the OK button to enter the main menu.
3. Select **Gas options**.
4. Select **Bump test**. A screen will open displaying the message, "Continue with bump test?"
5. Select **Yes**. EXO will run an audio/visual self test. See section 4.7 for more information.
6. A screen will prompt you to start the bump test. Ensure all the gas sensors you wish to bump test are selected. By default, EXO will test all sensors.
7. Select **Start bump**.
8. EXO will begin to count down from 60 seconds. Within this time window:

Tube connected to EXO's manual calibration inlet

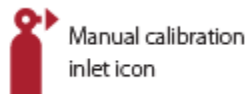

- Attach a tube fitted with a quick connect coupling insert to EXO's manual calibration inlet.
  - Confirm the other end of the tube is attached to the fixed flow regulator on the gas cylinder.
  - Turn on the gas regulator to apply the gas.
9. Turn the gas regulator off when prompted by EXO.
  10. You will be prompted to go through steps 6-9 until all sensors have been tested. The bump test procedure is only considered successful when all the sensors have been successfully tested.
  11. If all sensors have been successfully tested, press the OK button to complete the bump test. This screen will timeout after a few seconds. EXO will inform you if the bump test has passed or failed and when the next bump test is due.
  12. Remove the tube from the manual calibration inlet and let EXO sit until the gas readings stabilize. This may take a few minutes.

**If a bump test fails:**

- Check the gas and cylinder connections.
- Let EXO sit until its gas readings stabilize.

- Try the bump test again.

If the bump test continues to fail, contact your organization's safety supervisor.

## 8.2 CALIBRATION

---

Calibration ensures EXO's gas sensors can accurately detect gas levels through their operating life. During calibration, you apply a known concentration of gas for a set amount of time to adjust the sensors' parameters.

EXO automatically communicates the data collected from each calibration to Blackline Live when it is connected to the cellular or satellite network.

### Calibration schedule

The calibration schedule can be configured to match your company's safety policy. These changes are made in the configuration profile in Blackline Live. All the sensors on a cartridge will have the same calibration schedule, but if you choose to calibrate sensors individually, they can become due independent of the other sensors.

Blackline recommends calibrating all the sensors on a cartridge in a single calibration procedure.

On start-up, EXO will display when the sensors' next calibrations are due. By default, an overdue calibration will cause a reminder message to display in the banner on the gas status screen. This overdue response is configurable in Blackline Live.

**NOTE:** Blackline recommends not exceeding 180 days without a calibration.

### Gas cylinders

Sensors can be manually calibrated at the same time using one gas cylinder or individually using multiple gas cylinders. If using multiple cylinders, manual calibration will need to be repeated for each cylinder. In step 6 of the manual calibration procedure (section 8.2.1), ensure all the gas sensors that correspond to the attached cylinder's gas mixture are selected. The gas concentration of the connected gas cylinder should match the gas concentration listed in EXO's calibration gas configuration in Blackline Live.

**NOTE:** Some cartridges require you to calibrate sensors in a specific order due to gas sensor cross sensitivity. Refer to [G7 and EXO Gas Sensor Bump Testing and Calibration Order](#) on the Blackline Support site for more information.

### 8.2.1 MANUAL CALIBRATION

For a manual calibration, you will need:

- A cylinder or cylinders containing the appropriate gases
- A 0.5 LPM (or 1 LPM for Cl<sub>2</sub>, HCN, NO<sub>2</sub>, NH<sub>3</sub>, SO<sub>2</sub>, or H<sub>2</sub>S) fixed flow regulator attached to the cylinder(s)
- A tube fitted with a quick connect coupling insert

**NOTE:** If you are calibrating EXO Diffusion in a windy environment, you must use the wind guard. See section 1.2.3 for more information on using the wind guard.

#### To perform a manual calibration:

1. Ensure EXO is in clean air.
2. Press the OK button to enter the main menu.
3. Select **Gas options**.
4. Select **Calibration**. A screen listing the configured calibration settings will open, followed by a screen that says, "Continue with calibration?".
5. Select **Yes**. EXO will run an audio/visual self test. See section 4.7 for more information.
6. A screen will prompt you to zero the sensors. Ensure all the gas sensors you wish to calibrate are selected. By default, EXO will zero all sensors.
7. Select **Start zeroing**. All selected sensors will be zeroed in preparation for their calibration. This will take a few seconds.
8. A screen will prompt you to select a gas mix. Ensure all the gas sensors you wish to calibrate with the chosen gas cylinder are selected. By default, EXO will attempt to calibrate all sensors that have been successfully zeroed.
9. Select **Start span**.
10. EXO will begin to count down from 60 seconds. Within this time window:
  - Attach a tube fitted with a quick connect coupling insert to EXO's manual calibration inlet.

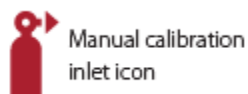

- Ensure the other end of the tube is attached to the fixed flow regulator on the gas cylinder.
  - Turn on the gas regulator to apply the gas.
11. Turn the gas off when prompted by EXO.



12. You will be prompted to go through steps 8 to 11 until all zeroed sensors have been calibrated. Calibration is only considered successful when all the sensors have been calibrated.
13. If all sensors have been successfully calibrated, you will be prompted to press the OK button to complete the calibration. This screen will timeout after a few seconds. EXO will let you know if the calibration has passed or failed and when the next calibration is due.
14. Remove the tube from the manual calibration inlet and let EXO sit until the gas readings stabilize.

If you see a "Calibration fail" message on EXO's screen:

- Check the gas and cylinder connections.
- Check that cylinder gas concentrations match the EXO calibration gas configuration.
- Let EXO sit until its gas readings stabilize.
- Try the calibration again.

If the calibration continues to fail, contact your organization's safety supervisor.

If you know EXO is in a clean atmosphere and a gas sensor is reading abnormal levels, this can mean the sensor's baseline has shifted, and EXO's displayed gas readings are not accurate. Try calibrating the sensor. If the sensor is still reading abnormal levels, you may need to zero the sensor.

## 8.3 ZERO SENSORS

---

If you are in a known clean environment with no gas and EXO's sensors are still displaying a gas reading, you can manually zero your sensors to reset the baseline. EXO can be configured to zero its sensors automatically on start-up and they are also zeroed as a part of the calibration procedure.

Contact your safety supervisor to learn more about how EXO's features are configured.

**NOTE:** LEL-MPS sensors must be started in clean air and zeroed upon start-up to function properly. See section 8.4 for more information about LEL sensors.

### 8.3.1 MANUAL ZERO SENSORS

You can zero a sensor by using the atmosphere to reset the sensor's baseline reading. Inert purge gas may also be applied to the manual calibration inlet to zero sensors.

- ▲ **WARNING:** EXO's sensors must only be zeroed with clean air. If a sensor is zeroed where its targeted gas levels are abnormal, the gas levels EXO displays will not be accurate. Inaccurate readings are a safety hazard.

To zero sensors:

1. Ensure EXO is in clean air.
2. Press the OK button to enter the main menu.
3. Select **Gas options**.
4. Select **Zero sensors**.
5. A screen will prompt you to zero the sensors. Ensure all the gas sensors you wish to zero are selected.
6. Select **Start zeroing**.
  - NOTE:** Do NOT apply gas.
7. A message will indicate when the zeroing is completed.

If you see a “Zero incomplete” message on EXO’s screen:

- EXO may be in an environment with abnormal gas levels.
- EXO’s cartridge may need to be replaced.

## 8.4 LEL SENSOR PRECAUTIONS

---

For safety reasons, EXO must be operated and serviced by qualified personnel only. Read and understand the information below before operating or servicing.

- ▲ **WARNING:** Off-scale (overlimit) readings may indicate an explosive concentration.
- ▲ **WARNING:** Calibrations must only be performed in areas free of flammable gases.

Blackline’s LEL sensors can be calibrated with the following settings:

Gas	Calibration concentration (%vol)	Calibration concentration (%LEL)	Balance
Methane (CH <sub>4</sub> )	2.5%	50% ±2%	Standard quad-gas mixture

No known gases desensitize or contaminate Blackline’s LEL-MPS and LEL-IR sensors. These two sensors do not cause any electromagnetic interference (EMI), and are not negatively affected by EMI, such as radio transmissions, of up to 8W.

Some compounds will decompose on the catalyst of the LEL-P and form a solid barrier over the catalyst surface. This action is cumulative, and prolonged exposure will result in an irreversible decrease in sensitivity. The most common of these substances are compounds containing lead or sulphur, silicones, and phosphates.

Some other compounds, especially hydrogen sulphide and halogenated hydrocarbons, are absorbed or form compounds that are absorbed by the catalyst of the LEL-P. The resulting loss of sensitivity is temporary. In most cases a sensor will recover after a period of operation in clean air.

Like any gas sensor, be sure to understand potential explosive hazards and choose the appropriate sensor technology based on these hazards.

Blackline Safety supports three different LEL sensor technologies:

- Molecular Property Spectrometer (LEL-MPS)
- Non-Dispersive Infra-Red (LEL-IR)
- Pellistor (catalytic bead) (LEL-P) (EU/UK only)

**NOTE:** LEL sensors cannot be disabled in Blackline Live.

### Molecular Property Spectrometer (LEL-MPS)

This sensor is not intended for inert environments. Environments with oxygen (O<sub>2</sub>) levels below 18% will negatively impact this sensor’s accuracy and Blackline does not recommend using it when oxygen levels are below 10%.

LEL-MPS sensors must be started in clean air and zeroed upon start-up to function properly. EXO devices equipped with LEL-MPS sensors cannot perform an automatic zeroing of the LEL-MPS sensor without manual confirmation.

LEL-MPS sensors must be started in clean air and zeroed upon start-up to function properly. EXO devices equipped with LEL-MPS sensors cannot perform an automatic zeroing of the LEL-MPS sensor without manual confirmation.



When powering on an EXO with an LEL-MPS sensor, the device will prompt you to acknowledge and approve that the device has been powered on in a clean air environment and a zero adjustment can take place. Should you fail to acknowledge the zero prompt within 15 seconds, your device will enter a latched alarm state and require that you power cycle the device and approve the zero prompt.



The clean air confirmation prompt is configurable in Blackline Live. If the clean air confirmation prompt is disabled, the device will prompt you to perform a manual zero adjustment.

When bump testing or calibrating this sensor, apply a gas mixture containing at least 18% oxygen (O<sub>2</sub>). Less oxygen than this may negatively impact the sensor's readings. If a gas mixture with less than 18% oxygen is applied during a bump test or calibration, restart EXO to auto zero the sensor.

This sensor can be calibrated two ways: default calibration and full calibration.

1. The default calibration procedure will validate and ensure accuracy without adjusting the LEL-MPS sensor's readings. Unlike traditional sensors, this sensor is factory-calibrated for optimal accuracy. We recommend using the factory calibration for the lifetime of the sensor.
2. Advanced users can perform a full calibration with a span adjustment. A full calibration may negatively impact the accuracy of other gases. EXO can be configured to run a full calibration on this sensor in Blackline Live.

### Non-Dispersive Infra-Red (LEL-IR)

This sensor can function in inert environments without oxygen. This sensor does not detect Hydrogen (H) or Acetylene (C<sub>2</sub>H<sub>2</sub>).

### Pellistor (catalytic-bead) (LEL-P)

Any rapid up-scale reading followed by declining or erratic reading may indicate a gas concentration beyond upper scale limit, which may be hazardous.

## 8.5 PID TARGET GASES

---

Photoionization detector (PID) sensors can be used to detect a large range of volatile organic compounds (VOCs). The PID sensor's target gas refers to whatever gas your device is currently attempting to detect. EXO's readings will be adjusted based on the gas it is currently configured to detect.

**NOTE:** Although PID sensors target a specific VOC, readings can still be affected by the presence of non-targeted gases. Consult your safety supervisor or industrial hygienist when preparing to use a PID sensor.

EXO's PID sensor's target gas is set from the configuration profile in Blackline Live. Under the Photoionization detector section of the Gas sensor settings card, you can choose an existing target gas or set a custom target gas.

The target gas EXO is configured to use can be seen in two places:

- On start-up
- In the gas options menu: Gas options > View gas info > VOC target

In both places EXO's screen will display the name of the target gas as well as its correction factor.

## 8.6 GAS ALERT COUNTDOWN

---

The gas alert countdown is an optional gas feature that creates a short delay before a high gas alert is delivered to Blackline Live and to monitoring personnel.

This feature will help to prevent false alarms from being delivered to monitoring services. Gases like CO and O<sub>2</sub> can spike and dip very quickly, setting EXO into high gas alarm even when gas levels go back to normal.

Typically, when a device's high gas threshold—determined in the configuration profile—is crossed, the device will immediately send an alert to Blackline Live. This is done so that monitoring personnel can investigate the incident and follow up with the device user to ensure their safety.

Since the alert is sent immediately, it can create false alarm scenarios where monitoring personnel will be alerted even though the exposure was momentary, and the device user is back in a safe area.

When the gas alert countdown feature is enabled, the device will wait a configured amount of time before sending the alert. EXO will still display red lights and a high urgency notification sound so the user knows to leave the immediate area.

With the gas alert countdown enabled, the banner at the top of the screen will show the remaining time before an alert is triggered in Blackline Live. If gas levels return to normal before this time has elapsed, the alert will be cleared. The gas exposure will still be visible in the device history view in Blackline Live but will not appear as an alert in the Alerts list.

The gas alert countdown feature is turned off by default.

### To enable the gas alert countdown:

1. Log into Blackline Live and go to the EXO configuration profile. In the gas sensor settings section under each individual sensor, there will be two settings:
  - A toggle labeled Gas alert countdown.
  - A dropdown field labeled Gas alert timeout.
2. Flip the toggle on for each sensor you want the countdown enabled for and determine the length of buffer time from the **Gas alert timeout** dropdown.



After the configuration is saved and the devices successfully receive the new settings, the gas alert countdown feature will be enabled.

## 9 GAS INLETS

### 9.1 MANUAL CALIBRATION INLET

---

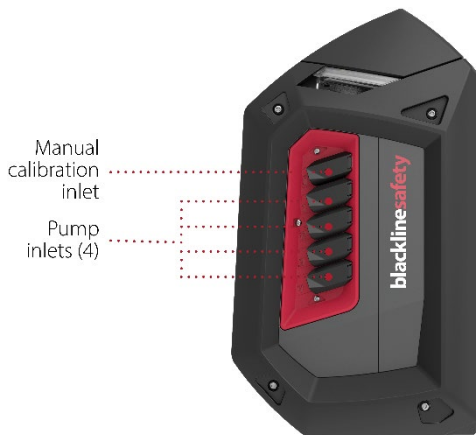

The manual calibration inlet allows you to apply gas to EXO's sensors during bump testing and calibration.

#### Fixed flow regulator

A gas cylinder with a fixed flow regulator is required to use the manual calibration inlet. This inlet relies on the gas pressure in the attached cylinder to bring the gas to the sensors.

#### Calibration cap

EXO does not need a calibration cap. The manual calibration inlet ensures the applied gas is fed directly to EXO's sensors.

**NOTE:** EXO cannot be bump tested or calibrated while a pump inlet is running (see section 9.2).

#### Attach tube

The manual calibration inlet is fitted with a quick connect coupling nozzle. Attaching a tube to this inlet requires the tube to have the corresponding quick connect coupling insert.

### 9.2 PUMP INLETS

---

EXO Pump inlets allow one EXO to monitor multiple remote areas using tubing. Inlets must be assigned before they are functional.

**NOTE:** Although EXO Pump inlet filters are an optional accessory, Blackline recommends always installing inlet filters to maintain the pump in good condition. See [EXO Pump Inlet Filters](#) on the Blackline Support site for more information.

To assign inlets:

1. Power on EXO and press OK to open the main menu.
2. Use the arrows and OK button to select **Gas options**.
3. Select **Inlet settings**. By default, the pump inlets (1-4) will display as OFF.
4. Attach a tube to the inlet you want to use. Each pump inlet is fitted with a quick connect nozzle. Attaching a tube to these inlets requires the tube to have a corresponding quick connect coupling insert.
5. Select **Inlet settings**, and then select the inlet you connected the tube to in step 4. Use the arrow buttons and OK to toggle the inlet to ON. This pump inlet is now functional.



Attaching a tube to an inlet

## Purge gas

When an inlet is toggled on, EXO spends two minutes purging. It draws in air to displace any gas that is currently inside EXO and in contact with the cartridge sensors. Gas readings are not available while EXO is purging.

▲ **WARNING:** Gas notifications will NOT be generated during a purge.

## 9.3 GAS SAMPLING

---

EXO Pump has four inlets to enable flexibility in gas sampling.

▲ **WARNING:** EXO Pump is not compatible with the following gases: Chlorine ( $\text{Cl}_2$ ) and Chlorine Dioxide ( $\text{ClO}_2$ ).

### Single gas sampling inlet

When one inlet is toggled on, EXO will continuously draw air in from that inlet.

▲ **WARNING:** If you start the pump while operating at temperatures of  $-20^\circ\text{C}$  ( $-4^\circ\text{F}$ ) or lower, EXO will generate a pump blocked alarm (see section 9.4) that persists until the inlet warms up and begins operating normally. In a multiple inlet sampling cycle, the inlets do not have time to warm up. For temperatures below  $-20^\circ\text{C}$  ( $-4^\circ\text{F}$ ), use only single gas sampling.

EXO will first purge for two minutes to clear out any gas from the sensors, then draw air from the inlet that has been turned on. When EXO draws from one inlet, it runs continuously from that inlet.

This setup is best for confined space entry, or any other situation where it is vital to continuously sample from a hazardous area.

### Multiple gas sampling inlets

When multiple inlets are toggled on, EXO will begin a sampling cycle.

To ensure you always know where gas exposures are coming from, EXO will only pull in gas from one inlet at a time. Note that when multiple inlets are toggled on, EXO will need to go through each inlet one at a time.

EXO will also need to purge in between each of the samples to displace gas from the previous sample. While EXO is purging itself, there will be gaps in readings.

A sample cycle typically looks like the following:

Purge > Sample from inlet 1 > Purge > Sample from inlet 2 > Purge > Sample from inlet 3.

Due to these gaps in readings, a multiple-inlet sample setup is best used for long-term monitoring of remote areas.

### Sample schedule

By default, the sample time from each inlet is three minutes. If you are running all four inlets with default settings (3 minute sample time + 2 minute purge time), there will be a 20 minute gap between readings from a given inlet.

The sample time can be extended in EXO's configuration profile in Blackline Live. Refer to the [Blackline Live Technical User Manual](#) for instructions.

### Pump automatically

By default, pumps remain off when EXO starts. You can change the EXO configuration profile in Blackline Live so pumps automatically turn on when EXO starts. Refer to the [Blackline Live Technical User Manual](#) for instructions.

## 9.4 PUMP BLOCKED

---

To ensure dust and debris do not get inside the device, EXO's pump inlets are closed when there is nothing connected to them. Turning on a pump inlet without a tube connected may result in a pump blocked notification to let you know there is no gas coming in from the inlet.



The pump blocked notification will also trigger when:

- Gas flow is restricted by something blocking the mouth of the tube.
- The tube gets bent or normal flow is obstructed.
- EXO is operating in temperatures of -20°C (-4°F) or colder.

A pump block detected event generates a low urgency notification and is logged in Blackline Live.

You can mute the notification by pressing and holding the up and down arrows, or by connecting an unobstructed tube to the inlet that is trying to pull in air. When an unobstructed tube is connected, the inlet will open to allow air flow, and the notification will end.

## 10 FEATURES

### 10.1 TEXT MESSAGES

---

EXO can send and receive text messages with monitoring personnel. You can send one of 10 pre-programmed messages or write a custom message. This message will be sent to Blackline Live as an alert. Pre-programmed messages are configurable in Blackline Live.

Messages can also be sent from Blackline Live and received by EXO. A low urgency notification will inform you of an incoming message.

**To send a pre-programmed message:**

1. Press the OK button to enter the main menu.
2. Select **Messages**.
3. Select **Send a message**.
4. Select a pre-programmed message. EXO will display a confirmation screen and then bring you back to the Gas status screen.

**To send a custom message:**

1. Press the OK button to enter the main menu.
2. Select **Messages**.
3. Select **Send a message**.
4. Select **Create custom**.
5. Press the up or down buttons to scroll through the alphabet and numbers.

6. Press the OK button to move to the next character.  
**NOTE:** Messages cannot exceed 16 characters.
7. Press the OK button again to finish the message.
8. Press the up button to continue editing, OK to send, or down to cancel.

#### To read received messages:

1. Press the OK button to enter the main menu.
2. Select **Messages**.
3. Select **Message inbox**.

## 10.2 TWO-WAY VOICE CALLS

---



If EXO has the two-way voice call feature enabled and is in cellular coverage, it can receive two-way voice calls from monitoring personnel as a response to high urgency notifications.

EXO automatically answers every voice call. You cannot initiate or end voice calls from EXO.

Monitoring personnel will initiate a voice call. If EXO is not already in a low urgency or high urgency state, it will inform you of the incoming call with a low

urgency notification. You will then hear a chirp indicating the voice call has been connected.

Speak directly to EXO. The microphone is located to the left of the SOS latch (see section 1.1.2 or 1.2.2, depending on your model). If monitoring personnel are having a hard time clearly hearing your responses, you may need to move closer to EXO. When monitoring personnel have confirmed you are safe, they will end the call and you will hear another chirp indicating the voice call has been disconnected.

**NOTE:** This feature is different from the push-to-talk (PTT) feature. Voice calls are not available when EXO uses the Iridium satellite network to connect to Blackline Live.

### Volume

Two-way calls use EXO's speaker. The speaker's volume cannot be adjusted. See section 4.9 for more information about the speaker.

## 10.3 PUSH-TO-TALK (PTT)

---

If EXO has the push-to-talk (PTT) feature enabled and is in cellular coverage, it can send and receive voice messages with other EXO devices and G7 wearable devices using the same channel, similar to a walkie-talkie. EXO can still receive and send PTT transmissions when it is locked by a maintenance code. See section 4.6 for more information on the maintenance code.

PTT only works when EXO is connected to Blackline Live through a cellular network. PTT does not work during a low urgency or high urgency notification state unless the notification has been muted. PTT only allows one transmission on a channel at a time.

### Volume

PTT uses EXO's speaker. The speaker's volume cannot be adjusted. See section 4.9 for more information about the speaker.

### To transmit PTT calls:

1. Press and hold the red latch.
2. When EXO finishes beeping, continue to hold and begin talking into the device.
3. When you are finished talking, release the latch. EXO allows PTT messages up to 30 seconds in length.
4. EXO will beep once more to let you know it is done listening.

### To receive a PTT call:

1. EXO will beep twice to signal an incoming PTT message.
2. EXO will play the message.
3. EXO will beep once more when the message is finished.

**NOTE:** EXO's screen will display its current channel.

## 10.4 AVAILABLE CHANNELS

---

### Channels 00 through 99

These channels are recommended for everyday use. When on a specific numbered channel, EXO:

- Transmits to devices on the same channel as EXO.
- Receives transmissions from devices on the same channel as EXO, as well as transmissions from devices in the All call channel.

## All call channel

This channel is recommended for safety supervisors or managers. The All call channel is the highest priority PTT channel. Incoming all call transmissions will override other PTT transmissions. When on the All call channel, EXO:

- Transmits to all PTT devices in EXO's organization.
- Receives transmissions from devices in the All call channel.

## Receive-only channel

When on the Receive-only channel, EXO:

- Cannot transmit to any devices.
- Receives transmissions from devices in the All call channel.

## 10.4.1 CHANGING CHANNELS

To change to a specific channel number:

1. Press the OK button to enter EXO's main menu.
2. Select **PTT channels**.
3. Select **Enter channel #**.  
**NOTE:** Every channel requires two digits
4. Use the up and down buttons to enter the first digit of the new channel. For example, for channel 08, the first digit is 0.
5. Press the OK button to move on to the next digit.
6. Use the up and down buttons to enter the second digit of the new channel. For example, for channel 08, the second digit is 8.
7. Press the OK button to finish.
8. Select **Yes** to confirm the new channel or select **Edit** to make changes.

To change to receive only or All call:

1. Press the OK button to enter EXO's main menu.
2. Select **PTT channels**.
3. Select **Receive only** or **All call**.
4. Read the message on the screen.
5. Select **Yes** to confirm.

## 10.5 AIRPLANE MODE

---

When EXO is being placed in an environment with no connectivity or an environment where radio frequency transmissions might be dangerous, EXO's Airplane mode allows you to disable all wireless communication to and from EXO.

When Airplane mode is on, EXO's notifications and alerts will still function, but they will not be communicated to Blackline Live, and the device will not receive any communications sent from other users or from staff monitoring devices. All events that EXO detects while in Airplane mode will be stored on EXO for up to 2 days, after which EXO will begin to overwrite the data, starting with the oldest. When Airplane mode is on, it will stay on until it is turned off, including through power cycles and longer periods of being powered down.

When Airplane mode is turned off and EXO connects to the network, all stored event data will be transmitted to Blackline Live. Refer to [Understanding Offline Data Storage for G7 Devices](#) for more details.

**NOTE:** If EXO is powered off then powered on while in Airplane mode, you will be prompted to confirm that you want Airplane mode to remain on. Select OK if you want to continue in Airplane mode.

**▲ WARNING:** When airplane mode is on, you cannot use the SOS latch or otherwise call for help using EXO.

To turn on airplane mode on EXO:

1. Press the OK button to enter the main menu.
2. Use the navigation buttons to scroll to **Advanced info**, then press OK.
3. Select **Airplane mode on**.

To turn off airplane mode on EXO:

1. Press the OK button to enter the main menu.
2. Use the navigation buttons to scroll to **Advanced info**, then press OK.
3. Select **Airplane mode off**.

## 10.6 STEALTH

---

When EXO is used in a known hazardous environment, EXO's Stealth functionality allows you to silence all audible and visual notifications and alerts. When Stealth is enabled, events will still be registered and sent to Blackline Live, but they will not be available on EXO itself.

▲ **WARNING:** When Stealth is enabled, the lights will not flash, the siren will not sound, and EXO will not indicate incoming voice calls. Blackline Safety recommends that you have an alternative channel of communication available when EXO is in Stealth.

The Stealth functionality must be enabled in Blackline Live by your company's administrator. When Stealth has been enabled for a configuration profile, it is enabled for all EXO devices on that profile and will stay enabled for all devices until it has been disabled in Blackline Live, including through power cycles and longer periods of being powered down.

**NOTE:** Blackline Safety must add this functionality before you see it in your Blackline Live organization. For more information, please contact Blackline [Technical Support](#).

## Alarms and Alerts

When EXO's Stealth is disabled in Blackline Live, EXO may go into low or high urgency notification due to a past event that occurred while EXO was in Stealth. SOS notifications must be cleared on the device.

## Push-to-Talk (PTT)

You can still use PTT to send messages when EXO is in Stealth, but the speaker is silenced so you will not hear incoming calls or PTT messages.

## Port A/B

When EXO is in Stealth, you will not be able to use Port A/B.

## 10.7 LOCAL TIME

---

EXO provides the option of showing the local time in the top right of the banner. Since this is also where the check-in timer is displayed, you will have the option to choose what information you would like to see if the check-in timer is enabled.

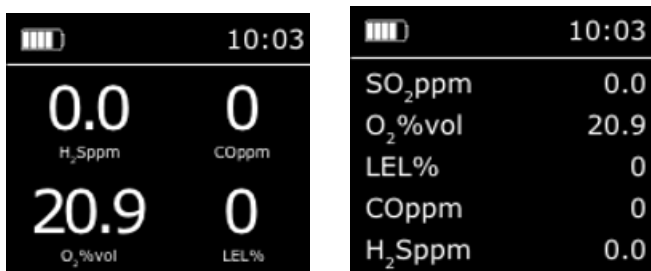

By default, if your EXO fleet is configured with the check-in timer enabled, the screen will display the check-in timer.

To display local time in the banner:

- 1. Press the OK button to open the main menu.
- 2. Use the up and down arrows to navigate to **Settings** and press OK to select.
- 3. Scroll down to **Banner**. You should see what the banner is currently set to.
  
- 4. To change the banner display, press the OK button and confirm the change. If the banner was previously set to Check-in, it should now be set to Time and vice versa. The new display option will be shown in-line with Banner.

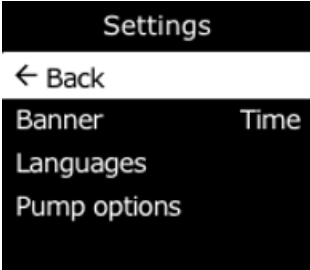
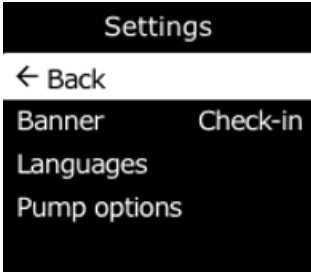

### 10.7.1 SETTING LOCAL TIME ON EXO

By default, the local time feature will use information gathered from nearby cell towers to determine the time zone and current time based on location, similar to how a cell phone operates.

However, a cellular connection may be unavailable, or your physical location might be on the border between time zones. In these cases, the default settings may provide inconsistent time zone information, and you may need to manually enter a time zone.

To manually enter a time zone:

**NOTE:** Time zone offsets are relative to Greenwich Mean Time (GMT: 0:00). You may need to look up the offset of your local time zone with respect to GMT — remember to consider daylight savings if your region uses it. The examples below use +1:30 as an offset.

- 1. Determine the offset relative to GMT for your local time zone.

2. Press OK to open the main menu. Use the up and down arrows to scroll to Time and press OK.
3. Select Time settings.

4. Enter + or -.



5. Enter the hour.

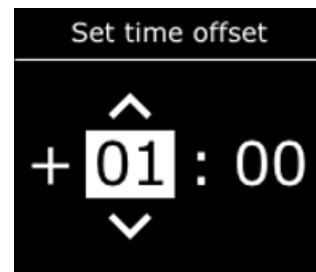

6. Enter minutes, if applicable.

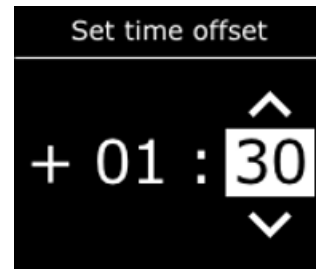

7. Select **Yes** to confirm, **Edit** to make changes, or **No** if you no longer want to set an offset.

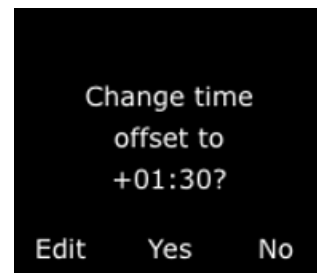

8. When you have input and confirmed the offset value, return to the Gas status screen. Confirm that the screen is displaying time based on the entered custom offset value.



To stop using a manual offset:

1. Press OK to open the main menu.
2. Select **Time**.
3. Select the **Auto** option. EXO will go back to using cellular information to determine the local time.

## 10.8 TIMER

---

To set the timer:

**NOTE:** The timer continues to count down even if you leave the screen.

1. Press OK to open the main menu.
2. Select **Time**.
3. Select **Timer**.
4. On the Set timer screen, select the unit of time (min or sec).
5. Use the up and down arrows to adjust the first digit for the time.
6. Press OK to select.
7. Repeat steps 5 and 6 to adjust the second digit for the time.

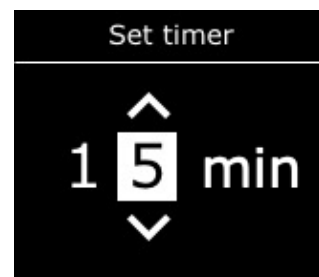
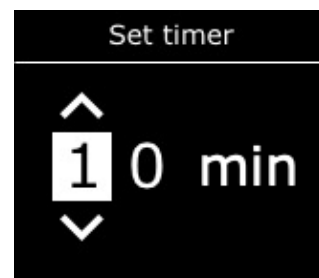

8. Select **Edit** to make changes or **Yes** to confirm the timer duration.

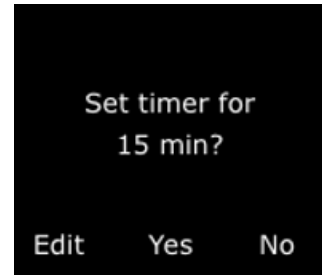

To view and stop the timer:

1. When the timer is set, view the remaining time in the Time menu, in-line with the Timer option.



2. To stop the timer early, go to Timer and select **Yes**.

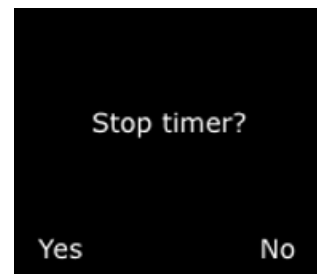

To stop the timer alarm:

1. When the timer counts down to 0, EXO will notify the user to check the screen. Press and hold the up and down arrows for three beeps to silence the alarm and clear the timer.



## 10.9 STOPWATCH

---

The stopwatch counts in one second increments. It does not time out or use an alarm. It continues to count in the background, even if you leave the stopwatch screen and return to the menu.

To set the stopwatch:

- 1. Press OK to open the main menu.
- 2. Select **Time**.
- 3. Select **Stopwatch**. The Stopwatch screen will open, showing the stopwatch at 00:00:00.



- 4. To start the stopwatch, select **Start**. You can navigate back to the main screen and the stopwatch will continue to run in the background.



- 5. To see how long the stopwatch has been running, open the **Time** menu.

The stopwatch will be displayed in-line with the Stopwatch option.



To pause or stop the stopwatch:

- 1. Open the Stopwatch screen.
- 2. Press the OK button to pause.

After pausing, the Stop option will change to **Resume**, and the option **Reset** will be available.



3. To resume the stopwatch, press the OK button.
4. To reset the stopwatch, press the up arrow.



## 11 ELECTRICAL PORTS

### 11.1 CAUTIONS



#### Ordinary Locations

When used in a non-Hazardous (Classified) Location, cables attached to the power port and Pins 1 and 2 of the A/B interface ports must be supplied by a Class 2 circuit, a limited energy circuit or a limited power source (LPS) as per IEC 61010-1, IEC 60950-1, or an equivalent IEC standard. The output should not exceed any of the applicable input entity parameters.

#### Follow local electrical codes

The wiring method used to install EXO's electrical port accessories should be in accordance with local electrical code. Installations are subject to acceptance by the authority having jurisdiction.

#### Barriers required

If the entity parameters in Diagram 11.5.4 and Diagram 11.5.5 exceed the requirements of your accessory, then a barrier is required for each interface port when EXO is in Class I, Division 1, Groups A,B,C,D location, or Class I, Zone 0/1, Group IIC location. See Diagram 11.5.6 for more information.

#### Intrinsic safety warning

Install EXO's electrical port accessories as shown in the electrical diagrams in sections 11.4.1 and 11.5.1 to ensure intrinsic safety.

## 11.2 DEFINITIONS

---

### Low-side switch

A low-side switch completes the circuit on the ground side. It is intended to sink power rather than provide power.

### $U_i$ – Maximum input voltage

The maximum voltage (peak a.c. or d.c.) that can be applied to the connection facilities of apparatus without invalidating the type of protection.

### $I_i$ – Maximum input current

The maximum current (peak a.c. or d.c.) that can be applied to the connection facilities of apparatus without invalidating the type of protection.

### $P_i$ – Maximum input power

The maximum power that can be applied to the connection facilities of apparatus without invalidating the type of protection.

### $C_i$ – Maximum internal capacitance

The maximum equivalent internal capacitance of the apparatus which is considered as appearing across the connection facilities.

### $L_i$ – Maximum internal inductance

The maximum equivalent internal inductance of the apparatus which is considered as appearing at the connection facilities.

### $U_o$ – Maximum output voltage

The maximum voltage (peak a.c. or d.c.) that can appear at the connection facilities of the apparatus at any applied voltage up to the maximum voltage.

### $I_o$ – Maximum output current

The maximum current (peak a.c. or d.c.) in apparatus that can be taken from the connection facilities of the apparatus.

### $P_o$ – Maximum output power

The maximum electrical power that can be taken from the apparatus.

### $C_o$ – Maximum external capacitance

The maximum capacitance that can be connected to the connection facilities of the apparatus without invalidating the type of protection.

**Lo – Maximum external inductance**

The maximum value of inductance that can be connected to the connection facilities of the apparatus without invalidating the type of protection.

**Lo/Ro – Maximum external inductance to resistance ratio**

Maximum value of ratio of inductance to resistance that can be connected to the external connection facilities of the electrical apparatus without invalidating intrinsic safety.

## 11.3 EXO TRANSLATOR

---

EXO Translator is an accessory that connects EXO to remote confined space monitoring systems and allows a central operating center service to directly monitor personnel and gas levels, access controls, and trigger alarms when necessary. For more information, see the [EXO Translator Technical User Manual](#).

## 11.4 POWER PORT

---

This electrical port allows EXO to connect to a power supply and charge its battery pack while it continues to monitor an area. Currently, two EXO accessories can be attached to this port:

- **Trickle Charger** allows EXO to be hardwired directly to a power source.
- **Solar Panel** allows EXO to be powered in remote areas through solar energy.
- ▲ **WARNING:** Cables attached to the power port are only intrinsically safe when properly set up with an electrical barrier.

### Cable requirements

EXO's power port is fitted with a male M12 4 pin plug. Electrical cables with a female M12 4 pin receptacle are required to connect to this port.

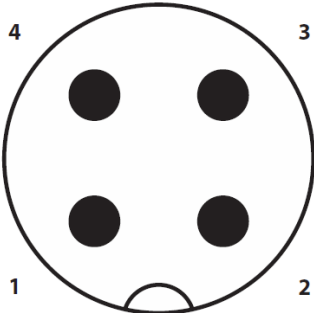

Diagram 11.4.1  
Power port schematic diagram  
Male plug  
Pin assignment M12 plug, 4-pos., A-coded, view plug side

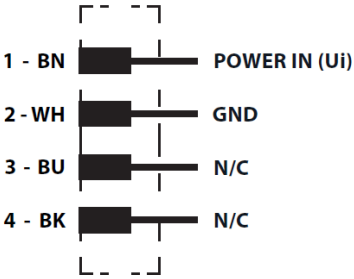

Diagram 11.4.2  
Power port circuit diagram  
Contact assignment of the M12 plug and M12 receptacles

### 11.4.1 INSTALLING ACCESSORIES

Install EXO power port accessories as shown in the following electrical diagram to ensure intrinsic safety.

Diagram 11.4.3

Power port parameters

**Hazardous (Classified) Location**

Class I, Division 1, Groups A,B,C,D  
or  
Class I, Zone 0, Group IIC

**Safe (Unclassified) Location**

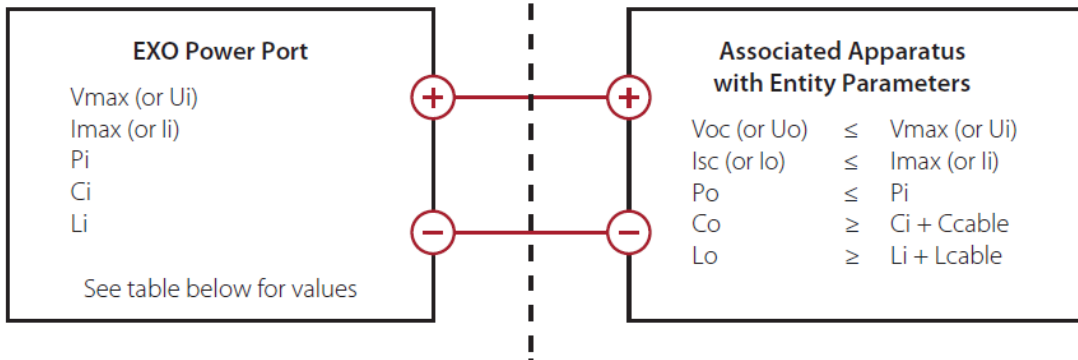

Power port input entity parameters

Terminal	Ui	Vmin	Ii	Pi	Ci	Li
Power port	16Vdc	10 Vdc	687mA	5300mW	0F	12.48uH

Functional input parameters for Power Port

Terminal	Ui	Ii	Pi	Ci	Li
Pin 1 to pin 2 (GND)	15 Vdc maximum	500mA	5300mW	0F	12.48uF



## 11.5 A/B INTERFACE PORTS

When events are triggered on EXO, A/B interface ports act as switches by sending ON or OFF signals to connected accessories. Ask your Blackline Safety distributor or sales representative for a list of EXO accessories that attach to the A/B interface ports.

Interface ports can be configured to activate when a high gas notification, low gas notification, text message, or AlertLink message event is triggered on the device.

Interface ports can also be configured to apply or remove power from connected accessories when an event occurs. For more information on configuring interface ports, refer to the [Blackline Live Technical User Manual](#).

### Cable requirements

Both of EXO's A/B interface ports are fitted with a female M12 4 pin receptacle. Electrical cables with a male M12 4 pin plug are required to connect to these ports.

### EXO versions and serial numbers

Two versions of the EXO have different output port parameters. High output EXOs have serial numbers 35880xxxxx, 35882xxxxx, or 35884xxxxx. All other serial numbers are low output EXOs.

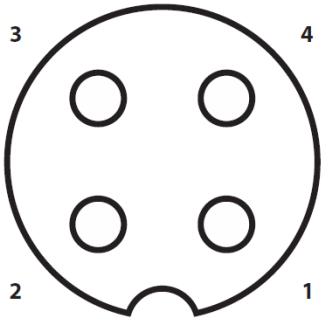

Diagram 11.5.1  
Interface port schematic diagram  
Female receptacle  
Pin assignment M12 socket, 4-pos., A-coded, view receptacle side

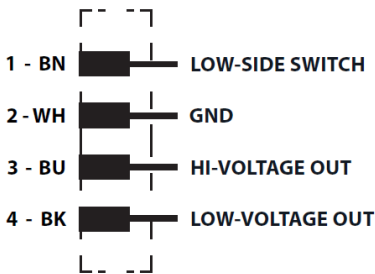

Diagram 11.5.2  
Interface port circuit diagram  
Contact assignment of the M12 plug and M12 receptacles

## 11.5.1 INSTALLING ACCESSORIES

Install EXO interface port accessories as shown in the following electrical diagrams to ensure intrinsic safety.

Diagram 11.5.3

### Interface port parameters – Low-side switch

**Hazardous (Classified) Location**

Class I, Division 1, Groups A,B,C,D  
or  
Class I, Zone 0, Group IIC

**Any Location Limited by Associated Apparatus Certification**

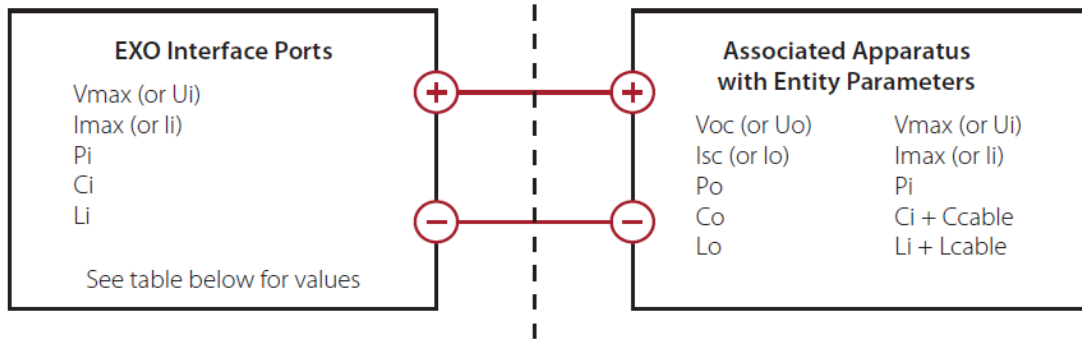

### Input entity parameters (low side switch)

Terminal	Ui	li	Pi	Ci	Li
Pin 1 to pin 2 (GND)	24Vdc	3.33A	1.25W	0F	0H

Diagram 11.5.4

Interface port parameters – pins 3 & 4

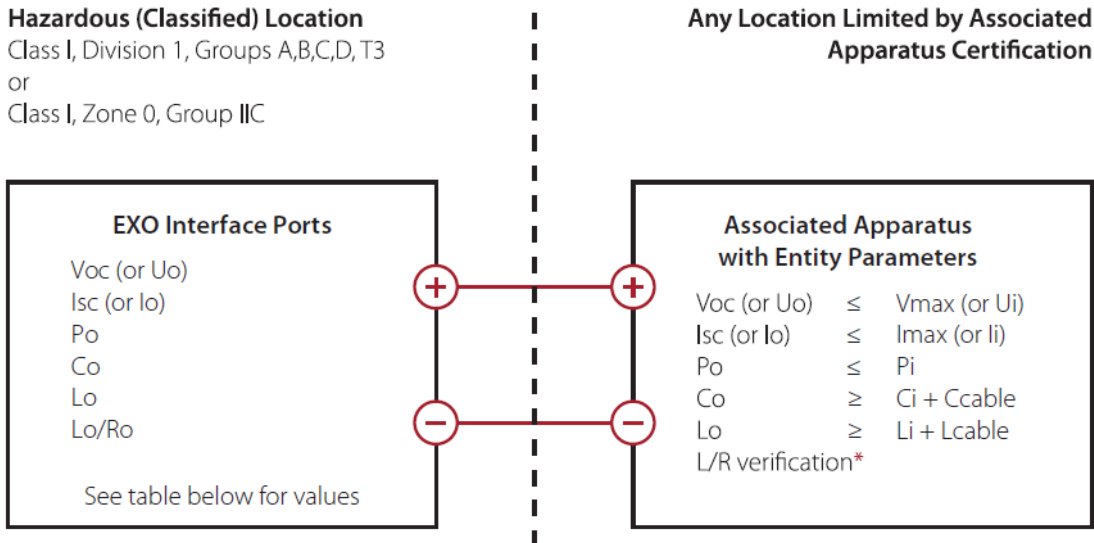

Output entity parameters - high output models (G7EXO-XX serial# 35880xxxxx, 35882xxxxx, 35884xxxxx)

Terminal	Uo	Io	Po	Co	Lo	Lo/Ro*
Pin 3 to pin 2 (GND)	20.76Vdc	268mA	1.39W	0.194uF	495uH	6.39uH/Ω
Pin 4 to pin 2 (GND)	4.94Vdc	108mA	97mW	100uF	3.05mH	91.68uH/Ω

Output entity parameters - low output models (G7EXO-XX – all non-high output model serial numbers)

Terminal	Uo	Io	Po	Co	Lo	Lo/Ro*
Pin 3 to pin 2 (GND)	20.76Vdc	93mA	0.479W	0.194uF	4.1 mH	18.2uH/Ω
Pin 4 to pin 2 (GND)	3.6Vdc	1.21A	3W	1000uF	24.3uH	21.9uH/Ω

\* Li may be greater than Lo and the cable length restrictions due to cable inductance (Lcable), and can be ignored if both of the following conditions are met:

$$Lo/Ro \geq Li/Ri$$

$$Lo/Ro \geq Lcable/Rcable$$

Diagram 11.5.5

Interface port functional parameters

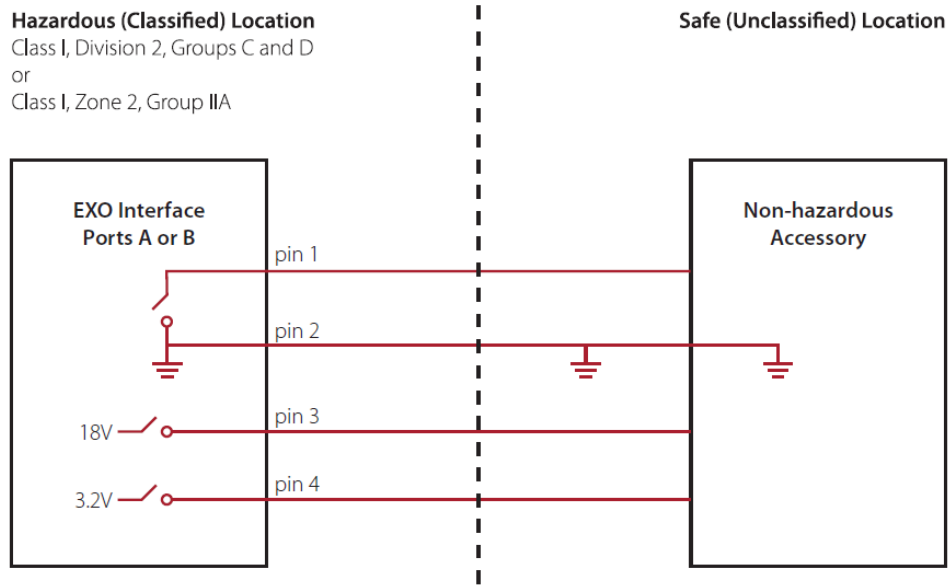

Functional output parameters for interface ports A and B - high output models  
(G7EXO-XX serial# 35880xxxx, 35882xxxx, 35884xxxx)

Terminal	Uo	Io <sup>†</sup>	Po <sup>†</sup>	Co	Lo
Pin 3 to pin 2 (GND)	18Vdc	268mA	850mW	0.194uF	495uH
Pin 4 to pin 2 (GND)	3.2Vdc	32mA	25mW	100uF	23.9uH

Functional output parameters for interface ports A and B - low output models  
(G7EXO-XX – all non-high output model serial numbers)

Terminal	Uo	Io <sup>†</sup>	Po <sup>†</sup>	Co	Lo
Pin 3 to pin 2 (GND)	18Vdc	48mA	479mW	0.194uF	4.1mH
Pin 4 to pin 2 (GND)	3.2Vdc	1000mA	3.0W	1000uF	24.2uH

<sup>†</sup>Io and Po will be reduced if both pin 3 and pin 4 are used simultaneously.

Functional input parameters (low side switch) for interface ports A and B

Terminal	Ui	Ii	Pi	CI	Li
Pin 1 to pin 2 (GND)	24Vdc	3.33A	1.25W	0F	0H

Diagram 11.5.6

Interface port functional parameters with barriers

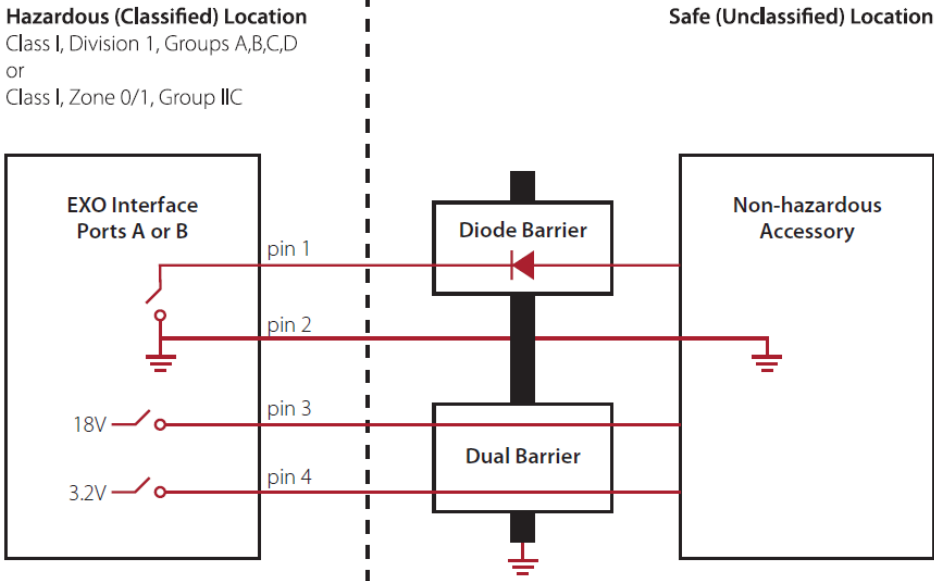

**NOTE:** A barrier is required for each interface port. The diode barrier and dual barrier can be individual units or a joint unit.

Functional output parameters for interface ports A and B - high output models (G7EXO-XX serial# 35880xxxx, 35882xxxx, 35884xxxx)

Terminal	U <sub>o</sub>	I <sub>o</sub> <sup>†</sup>	P <sub>o</sub> <sup>†</sup>	C <sub>o</sub>	L <sub>o</sub>
Pin 3 to pin 2 (GND)	18Vdc	268mA	850mW	0.194uF	495uH
Pin 4 to pin 2 (GND)	3.2Vdc	32mA	25mW	100uF	23.9uH

Functional output parameters for interface ports A and B - low output models (G7EXO-XX – all non-high output model serial numbers)

Terminal	U <sub>o</sub>	I <sub>o</sub> <sup>†</sup>	P <sub>o</sub> <sup>†</sup>	C <sub>o</sub>	L <sub>o</sub>
Pin 3 to pin 2 (GND)	18Vdc	48mA	479mW	0.194uF	4.1mH
Pin 4 to pin 2 (GND)	3.2Vdc	1000mA	3.0W	1000uF	24.2uH

<sup>†</sup>I<sub>o</sub> and P<sub>o</sub> will be reduced if both pin 3 and pin 4 are used simultaneously.

Functional input parameters (low side switch) for interface ports A and B

Terminal	U <sub>i</sub>	I <sub>i</sub>	P <sub>i</sub>	C <sub>i</sub>	L <sub>i</sub>
Pin 1 to pin 2 (GND)	24Vdc	3.33A	1.25W	0F	0H

## 12 OVER-THE-AIR FIRMWARE UPDATES

To offer new features, Blackline Safety periodically releases over-the-air (OTA) firmware updates. OTA firmware updates are only available when EXO is on a cellular network.

Firmware updates have two steps:

- Automatic download
- Automatic installation

### Automatic download

When a firmware update is released, EXO will gradually download the update whenever it is on and connected to a cellular network. EXO will be ready to install the firmware update when the download is complete. This will not interfere with normal EXO use.

### Automatic installation

The completely downloaded update will automatically be installed the next time EXO is powered on. This installation will add 30-60 seconds to the start-up sequence.

When the green light is solid and EXO is connected, it will automatically power down. The top lights will then flash red and yellow, and the device will be unresponsive. After 30-60 seconds, EXO will power back up and display the new firmware version it has downloaded.

Once firmware is installed, EXO will continue to monitor as usual.

**▲ WARNING:** EXO will NOT monitor when firmware is installing.

Specific information about new updates can be found on the [Blackline Support site](#). If you have any questions, please contact Blackline [Technical Support](#).

## 13 SUPPORT

### 13.1 LEARN MORE

---

Visit [support.blacklinesafety.com](https://support.blacklinesafety.com) to find more support and training materials for EXO.

### 13.2 TECHNICAL SUPPORT

---

For technical support, please contact our Technical Support team.

**North America (24 hours)**

Toll Free: 1-877-869-7212 | [support@blacklinesafety.com](mailto:support@blacklinesafety.com)

**United Kingdom (8am-5pm GMT)**

+44 1787 222684 | [eusupport@blacklinesafety.com](mailto:eusupport@blacklinesafety.com)

**International (24 hours)**

+1-403-451-0327 | [support@blacklinesafety.com](mailto:support@blacklinesafety.com)

# 14 SPECIFICATIONS

## 14.1 DETAILED SPECIFICATIONS

### Functional settings

SOS latch: Pull latch to trigger SOS alert  
 Low battery: Configurable threshold  
 Connection lost: Configurable time period  
 Two-way messages: Custom messages and 10 preconfigured sent to monitoring personnel  
 Maintenance code: Configurable 4 digits  
 Push-to-talk: Send and receive voice messages to other G7 and EXO devices

### Gas cartridge features

High gas alert  
 Low gas warning alarm  
 Under limit (UL)  
 Over limit alerts (OL)  
 Bump test and calibration notification  
 Bump test and calibration failure

### Size & weight

Material: Rugged housing built from aluminum, plastic, and rubberized bumpers  
 Size (without battery): 385 mm x 188 mm x 220 mm (15.1" x 7.4" x 8.7")  
 Weight (without battery): 12.25Kg 27 lbs

### User interface

Display: 4.4" diagonal, 480 by 640 pixel, eight-colour active matrix liquid crystal display (LCD)  
 Menu system: Driven by three-button keypad,  
 Power button: On/Off  
 SOS latch: Send SOS alert  
 Multi-language support: EN, FR, ES, DE, IT, NL, PT

### User notification

Green connectivity light: Blinking (powered), continuous (connected)  
 360-degree visible yellow and red lights  
 Yellow light: Operational and low urgency notifications  
 Red light: High urgency notifications  
 Blue LiveResponse™ indicator light: Confirmation that a monitoring team has acknowledged a notification  
 AlertLink: Notification that another device within the proximity radius is experiencing a high urgency event

### Wireless updates

Device configuration changes: Yes  
 Device firmware upgrade (OTA): Yes

### Cellular wireless radio

Wireless coverage: 100 countries, 200 wireless carriers  
 North America: 3G/4G radio; 3G UMTS bands 2 and 5; 4G bands 2, 4 and 5  
 International: 2G/4G radio; 2G GSM bands E-GSM and PCS; 4G bands 3, 7 and 20  
 Asia Pacific: 3G/4G radio; 3G UMTS band 1; 4G bands 3, 8 and 28  
 Antenna: Internal

### Satellite module

User-upgradeable satellite module allows EXO to connect to the iridium satellite network for remote areas outside of cellular connectivity.  
 Optional module: Yes  
 Network: Iridium, global coverage  
 Radio: 1621 MHz, 2 Watts  
 Antenna: Internal

### Location technology

Multi-constellation: GPS/QZSS, Galileo, BeiDou  
 Receiver type: 72-channel  
 Assisted-GNSS: Yes  
 GNSS Accuracy: 5 m (16 feet), CEP 50%, 24 hours static

### EXO Pump

Number of pump channels: 4  
 Sampling period per channel: Adjustable  
 Tube length per channel: Up to 30 m (100 ft)

### Power & battery

Rechargeable battery capacity: 144 Ah (LiFePO4)  
 Battery life in diffusion mode: 100 days at 20°C (68°F), LEL-IR, H<sub>2</sub>S, CO and O<sub>2</sub> config.  
 Battery life in pump mode: 30 days at 20°C (68°F), LEL-IR, H<sub>2</sub>S, CO and O<sub>2</sub> config.  
 Charge time: ~12 hr  
 Intrinsicly safe power port: Yes, supports EXO continuous operation

### Blackline Live web application

Cloud-hosted safety monitoring web application is highly customizable for every customer requirement. Includes live map, employee address book, user roles, alert management, device configurations, alert setups, and reporting

### A/B interface ports

Intrinsicly safe, configurable external signal ports designed to integrate with external alarms and electrical systems  
 Four pins per interface port  
 High Output Models:  
 Pin 1: Low side switch  
 Voc=24Vdc, Isc=3.33A, Co=0F, Lo=0H  
 Pin 2: Ground  
 Pin 3: High voltage out  
 Voc=18Vdc, Isc=268mA, Co=0.194uF, Lo=495uH  
 Pin 4: Low voltage out  
 Voc=3.2Vdc, Isc=32mA, Co=100uF, Lo=23.9uH  
 Low Output Models:  
 Pin 1: Low side switch  
 Voc=24Vdc, Isc=3.33A, Co=0F, Lo=0H  
 Pin 2: Ground  
 Pin 3: High voltage out  
 Voc=18Vdc, Isc=48mA, Co=0.194uF, Lo=4.1mH  
 Pin 4: Low voltage out  
 Voc=3.2Vdc, Isc=100mA, Co=100uF, Lo=24.2uH

### Environmental

Storage temperature: -40°C to 60°C (-40°F to 140°F)  
 Operating temperature: -20°C to 50°C (-4°F to 122°F)  
 Charging temperature: 0°C to 45°C (32°F to 113°F)  
 Ingress Protection: Designed to meet IP65

### Approvals

RoHS, CE, RCM  
 Canada & USA: Class I Division 1 Group A,B,C,D T3;  
 Class I Zone 0 AEX ia IIC T3; Ex ia IIC T3 Ga  
 IECEx: Ex ia IIC T3 Ga  
 ATEX: Ex ia IIC T3 Ga  
 LEL: CSA C22.2 No.152; ISA 12.13.01  
 FCC ID: W77EXO IC: 8255A-EXO  
 Contains:  
 FCC ID: XPY1EIQ24NN, Q639603N  
 IC: 8585A-1EIQ24NN, 4629A-9603N

### Warranty

EXO area monitor: three-year hardware warranty, extended warranty available  
 Blackline complete lease option; provides comprehensive warranty for full term



## 14.2 WIRELESS SPECIFICATIONS

	4G G7EXO NA		4G G7EXO Europe		4G G7EXO AUS/NZ
Model:	G7EXO-NA2	G7EXO-NA2	G7EXO-EU2	G7EXO-EU2	G7EXO-AZ2
Unit ID Start:	35880xxxxx 35881xxxxx	35890xxxxx	35882xxxxx 35883xxxxx	35892xxxxx	35884xxxxx 35885xxxxx
<b>Cellular Radio</b>					
Coverage	172 Countries, 306 Operators				
Bands	4G LTE 12, 2, 4, 5 3G UMTS 850/1900	4G LTE 1, 12, 13, 18, 19, 2, 20, 26, 28, 3, 38, 39, 4, 40, 41, 5, 7, 8 3G UMTS 1900, 2100, 850, 900 2G GSM 850/900/1800/1900	4G LTE bands 20, 3, 7 2G GSM 900/1800	4G LTE 1, 12, 13, 18, 19, 2, 20, 26, 28, 3, 38, 39, 4, 40, 41, 5, 7, 8 3G UMTS 1900, 2100, 850, 900 2G GSM 850/900/1800/1900	4G 3,8,28 3G UMTS 2100
Approvals	Contains FCC ID: XPY1EIQ24NN IC: 8585A-1EIQ24NN	Contains: FCC ID: XPYUBX21BE01 IC: 8595A-UBX21BE01	CE, UKCA	CE, UKCA	RCM
Antenna	Internal				
<b>Bluetooth</b>					
Version	4.2 BR/BLE				
Band	2.4 GHz				
Approvals	FCC ID: W77EXO IC: 8255A-EXO	FCC ID: W77EXO IC: 8255A-EXO	CE, UKCA	CE, UKCA	RCM
Antenna	Internal				
<b>Satellite Radio</b>					
Network	Iridium				
Band	1616-1626.5 MHz				
Approvals	FCC ID: Q639603N IC: 4629A-9603N				
Antenna	Internal				
<b>Location Technology</b>					
Constellations	GPS				
Receiver type	72-channel				
Assisted-GNSS	Yes				
Accuracy	5 meters, CEP 50%, 24 hours stationary sky-view				
Antenna	Internal				
Indoor location technology	Blackline Safety location beacons				
Location update frequency	30 minutes				

## 14.3 GAS SENSOR SPECIFICATIONS

Gas	Sensor Type	Range	Resolution
Ammonia (NH <sub>3</sub> )	Electrochemical	0-100 ppm	0.1 ppm
High-range ammonia (NH <sub>3</sub> )	Electrochemical	0-500 ppm	1 ppm
Carbon monoxide (CO)	Electrochemical	0-500 ppm	1 ppm
High-range carbon monoxide (CO)	Electrochemical	0-2000 ppm	5 ppm
Hydrogen resistant carbon monoxide (CO-H)	Electrochemical	0-500 ppm	1 ppm
Carbon dioxide (CO <sub>2</sub> )	NDIR	0-50,000 ppm	50 ppm
Chlorine (Cl <sub>2</sub> )*	Electrochemical	0-20 ppm	0.1 ppm
Chlorine dioxide (ClO <sub>2</sub> )*	Electrochemical	0-2 ppm	0.01 ppm
COSH (CO & H <sub>2</sub> S)	Electrochemical	0-500 ppm CO, 0-100 ppm H <sub>2</sub> S	1 ppm CO, 0.1 ppm H <sub>2</sub> S
Hydrogen (H <sub>2</sub> ) (UK/EU only)	Electrochemical	0-40,000 ppm	1% LEL (400 ppm H <sub>2</sub> )
Hydrogen cyanide (HCN)	Electrochemical	0-30 ppm	0.1 ppm
Hydrogen sulphide (H <sub>2</sub> S)	Electrochemical	0-100 ppm	0.1 ppm
High-range hydrogen sulphide (H <sub>2</sub> S)	Electrochemical	0-500 ppm	0.5 ppm
LEL-infrared (LEL-IR)	NDIR	0-100% LEL	1% LEL
LEL-molecular property spectrometer (LEL-MPS)	MPS	0-100% LEL	0.1% LEL
LEL-pellistor (LEL-P) (UK/EU Only)	Catalytic bead	0-100% LEL	1% LEL
Nitrogen dioxide (NO <sub>2</sub> )	Electrochemical	0-50 ppm	0.1 ppm
Oxygen (O <sub>2</sub> )	Pumped electrochemical	0-25% vol	0.1% vol
Photoionization (PID)	PID	0-4,000 ppm	Dynamic resolution**, 0.1 ppm
Sulfur dioxide (SO <sub>2</sub> )	Electrochemical	0-100 ppm	0.1 ppm

\*Sensor does not work with EXO Pump

\*\* Dependent on correction factor

**NOTE:** Check with Blackline for approval status. All specifications subject to change.

# 15 LEGAL NOTICES AND CERTIFICATIONS

## 15.1 LEGAL NOTICES

---

Information in this document is subject to change without notice. This document is provided "as is" and Blackline Safety Corp. ("Blackline") and its affiliated companies and partners assume no responsibility for any typographical, technical, or other inaccuracies in this document. Blackline reserves the right to periodically change information that is contained in this document. However, Blackline makes no commitment to provide any such changes, updates, enhancements, or other additions to this document to you in a timely manner or at all.

Copyright © 2020 Blackline Safety Corp. All rights reserved.

Except as expressly provided herein, no part of this manual may be reproduced, copied, transmitted, disseminated, downloaded, or stored in any storage medium, for any purpose without the express prior written consent of Blackline Safety Corp ("Blackline"). Blackline hereby grants permission to download a single copy of this manual onto some form of electronic storage medium to be viewed and to print one copy of this manual or any revision hereto, provided that such electronic or printed copy of this manual must contain the complete text of this copyright notice. Further, any unauthorized commercial distribution of this manual or any revision hereto is strictly prohibited.

The Blackline, Alert, Locate, Respond, Families of related marks, images, and symbols, including Blackline, G7, G7c, G7x, EXO, LiveResponse, Loner, LonerIS, Loner IS+, Loner M6, Loner M6i, Loner Mobile, Loner 900, and SureSafe are the exclusive properties and trademarks of Blackline Safety Corp. All other brands, product names, company names, trademarks and service marks are the properties of their respective owners.

### Warranty

Your EXO device is warranted against defects in materials and workmanship for up to three years from date of purchase. For further

details regarding your Blackline warranty, please refer to your terms and conditions of service.

### FCC Compliance

This device complies with part 15 of the FCC Rules. Operation is subject to the following two conditions: (1) This device may not cause harmful interference, and (2) this device must accept any interference received, including interference that may cause undesired operation.

**NOTE:** The grantee is not responsible for any changes or modifications not expressly approved by the party responsible for compliance. Such modifications could void the user's authority to operate the equipment.

**NOTE:** This equipment has been tested and found to comply with the limits for a Class B digital device, pursuant to part 15 of the FCC Rules. These limits are designed to provide reasonable protection against harmful interference in a residential installation. This equipment generates, uses, and can radiate radio frequency energy and, if not installed and used in accordance with the instructions, may cause harmful interference to radio communications. However, there is no guarantee that interference will not occur in a particular installation. If this equipment does cause harmful interference to radio or television reception, which can be determined by turning the equipment off and on, the user is encouraged to try to correct the interference by one or more of the following measures:

- Reorient or relocate the receiving antenna.
- Increase the separation between the equipment and receiver.
- Connect the equipment into an outlet on a circuit different from that to which the receiver is connected.
- Consult the dealer or an experienced radio/TV technician for help.

This device is compliant with radio frequency radiation exposure regulations for mobile devices. As such, a separation of at least 20 cm must be normally maintained between the device and nearby persons.

### Industry Canada Compliance

This device complies with Industry Canada license-exempt RSS standard(s). Operation is subject to the following two conditions: (1) this device may not cause interference, and (2) this device must accept any interference, including interference that may cause undesired operation of the device.

### Notification d'Industrie Canada

Ce dispositif est conforme au(x) format(s) RSS libre(s) d'Industrie Canada. Son fonctionnement est assujéti aux deux conditions suivantes : (1) Cet appareil ne peut causer d'interférences nuisibles, et (2) cet appareil doit accepter toute interférence reçue, y compris les interférences pouvant provoquer un mauvais fonctionnement du dispositif.

### Warning

Do not operate Blackline Safety products where you are not able to safely operate your mobile/cellular phone.

Electrical equipment may be hazardous if misused. Operation of this product, or similar products, must always be supervised by an adult. Do not allow children access to the interior of any electrical product and do not permit them to handle any cables.

Do not operate or store Blackline products outside their specified operating or storage temperatures. Consult 13 for more information.

Blackline products may contain an internal lithium-ion battery pack. Seek advice from your local electronics recycling authority regarding the disposal of your device. Do not dispose of Blackline products in your household trash.

## 15.2 INTRINSICALLY SAFE CERTIFICATION

The enclosure is manufactured from aluminium, magnesium, titanium, or zirconium which may be used at the accessible surface of the equipment. In rare cases, ignition sources due to impact and friction sparks could occur. This shall be considered when the EXO is being installed in Zone 0 locations for group II level of protection Ga.

### Intrinsically Safe

This device is certified Intrinsically Safe for use in Class I Division 1 Groups A,B,C,D T3; Ex ia IIC T3 Ga; Class I Zone 0 AEx ia Group IIC T3 Ga hazardous (classified) locations.

MC 267256

UL 60079

Class I Division 1 Groups A,B,C,D; T3

Class I Zone 0 AEx ia IIC T3 Ga

CAN/CSA C22.2 No. 60079

Ex ia IIC T3 Ga



IECEX/ATEX/UKCA: IECEX SIR 20.0022X; Sira 20ATEX2004X; CSAE 21UKEX2218X

IEC 60079; EN 60079

Ex ia IIC T3 Ga



2813



II 1 G



0518

$-20^{\circ}\text{C} \leq T_{\text{amb}} \leq +50^{\circ}\text{C}$

Base unit P/N: G7EXO-XXY

Where XX is a regional code and Y is a radio technology code

### Caution

For safety reasons this equipment must be operated and serviced by qualified personnel only. High off-scale readings may indicate explosive concentration.

The equipment shall only be charged when in the non-hazardous area using a charger specifically supplied for use with the unit (for example part number JAC2504L-XX, manufactured by Schauer Battery Chargers), approved as SELV or Class 2 equipment against IEC 60950, IEC 61010-1 or an equivalent IEC standard. The maximum voltage and current from the charger shall not exceed 5Vdc and 25A respectively.

The enclosure is manufactured from Aluminium, magnesium, titanium or zirconium which may be used at the accessible surface of the equipment. In rare cases, ignition sources due to impact and friction sparks could occur. This shall be considered when the EXO is being installed in Zone 0 locations for group II level of protection Ga.

Consult with your organization's safety professional for further information regarding the topic of intrinsic safety and any policies, procedures, facilities, or locations within facilities that may be related to intrinsic safety.

### Sécurité intrinsèque

Cet appareil est certifié à sécurité intrinsèque pour l'usage en classe I division 1 groupe A,B,C,D T3; Ex ia IIC T3 Ga; classe I zone 0 AEx ia groupe IIC T3 Ga dans les lieux classés comme dangereux.

### Standards:

CAN/CSA C22.2 No. 60079-0: 2019

CAN/CSA C22.2 No. 60079-11: 2014

C22.2 No. 152 - M1984 (R2011)

UL 913, Eighth Edition

UL 60079-0: Sixth Edition

UL 60079-11: Sixth Edition

ANSI/ISA 12.13.01: 2000

EN 60079-0: 2018

EN 60079-11: 2012

IEC 60079-0: 2011 6th Edition

IEC 60079-11: 2011 6th Edition

### Attention

Pour des raisons de sécurité, cet équipement doit être utilisé, entretenu et réparé uniquement par un personnel qualifié. Des lectures supérieures à l'échelle peuvent indiquer des concentrations explosives.

L'équipement ne doit être chargé que dans la zone non dangereuse à l'aide d'un chargeur spécifiquement fourni pour l'utilisation avec l'appareil (par exemple, la référence JAC2504L-NA, fabriquée par Schauer Battery Chargers) SELV ou Classe 2 selon IEC 60950, IEC 61010-1 ou une norme IEC équivalente. La tension et le courant maximum du chargeur ne doivent pas dépasser respectivement 5Vdc et 25A.

S'il vous plaît consulter un professionnel de la sécurité de votre organisation pour de plus amples informations concernant le sujet de la sécurité intrinsèque et les politiques, les procédures, les installations, ou emplacements au sein des établissements qui peuvent être liés à la sécurité intrinsèque.

# 15.1 INMETRO CERTIFICATION

---

INMETRO - Certificate BRA 22.GE0002X, Ex ia IIC T3 Ga